



YOUTH VIOLENCE  
SYSTEMS PROJECT  
*Getting to the Roots*

SPECIAL EDITION REVIEW

A PARTNERSHIP OF

Emmanuel Gospel Center  
Black Ministerial Alliance of Greater Boston  
Boston TenPoint Coalition  
High Risk Youth Network  
United Way of Massachusetts Bay and Merrimack Valley

© 2011 Emmanuel Gospel Center  
[www.gettingtotheroots.org](http://www.gettingtotheroots.org)



**The Youth Violence Systems Project (YVSP)** was initiated to empower the community's perspective on youth violence in Boston by creating a framework for developing intervention strategies that lead to real change. Since 2008, YVSP has been using a community-based approach coupled with systems dynamics modeling to create a virtual laboratory to model youth violence intervention strategies. Our goal is to help develop the capacity for deep and honest dialogue among a wide range of people to collaborate toward a shared goal of reducing youth violence in our neighborhoods.

## PAGE 1

---

*The Youth Violence Systems Project: A Community-Based Framework of Understanding Youth Violence in Boston* gives an overview of the community-based process that is at the heart of YVSP. It also gives a brief introduction to the content covered in more depth in the other three articles.

## PAGE 22

---

*The YVSP Strategy Lab* describes YVSP's system dynamics model in detail, including an introduction to the key systems concepts for understanding the model.

## PAGE 34

---

*The Reason Why We Haven't Solved the Gang Violence Problem* discusses how the YVSP team solicited the input of gang members in the design process, and describes the findings and insights gained.

## PAGE 50

---

*What We Are Learning* describes how the model is being used in various settings, and what different folks are learning from the discourse so far.

*YVSP has been and is possible by the generous contributions and donations of organizations and individuals. If you are interested in supporting this project in any way, please contact Sam Kim, Project Director, 617-262-4567, skim@egc.org.*



## THE YOUTH VIOLENCE SYSTEMS PROJECT: A Community-Based Framework of Understanding Youth Violence in Boston

The Youth Violence Systems Project (YVSP) was initiated to empower the community's perspective on youth violence in Boston by creating a framework for developing intervention strategies that lead to real change. Since 2008, YVSP has been using a community-based approach coupled with systems dynamics modeling to create a virtual laboratory to model youth violence intervention strategies. Our goal is to help develop the capacity for deep and honest dialogue among a wide range of people to collaborate toward a shared goal of reducing youth violence in our neighborhoods.

This article gives an overview of the community-based process that is at the heart of YVSP. In addition, the story of the YVSP process is further told in three related articles:

- **The YVSP Strategy Lab** describes YVSP's system dynamics model in detail, including an introduction to the key systems concepts for understanding the model.
- **The Reason Why We Haven't Solved the Gang Violence Problem** discusses how the YVSP team solicited the input of gang members in the design process, and describes the findings and insights gained.
- **What We Are Learning** describes how the model is being used in various settings, and what different folks are learning from the discourse so far.

The Youth Violence Systems Project (YVSP) incorporates community, academic, and institutional perspectives on the interrelated causes of youth violence in Boston. It came about through the confluence of four streams: thoughtful conversations, passionate people, key partnerships, and funding. People based in a wide range of fields (like active community members, non-profit community organizations, churches, law enforcement, public health, etc.) are highly motivated to see a reduction in youth violence. Ideally, these groups would collaborate, but they have historically been hindered by the lack of a shared framework of understanding. The goal of YVSP was to create just such a framework through community-based research and a system dynamics approach. To be successful it had to rely on the wisdom and experience of the communities most affected by youth violence, including the youth themselves.



“The model becomes a tool that can be used by people who weren't in the planning process. Folks in the community can sit down and talk about youth violence together. Anything that would help create a way for people to come to an understanding of the root causes of youth violence would be helpful. Creating tools that people could use that help us think beyond the knee-jerk response.”

—Design Team Member



“I think that leaving the model in the hands of the community is the right approach. They have the insight to the issue and the interventions they think will work.” —*Design Team Member*

What follows is the story of YVSP from its beginning as a compelling conversation in a Boston Capacity Tank meeting to its current broad training work. Members of three key communities, professionals from different fields, and a multi-disciplinary steering committee worked together to create a computer simulation model and the accompanying shared framework of youth violence in Boston. Much of what we have learned together through the last few years of this Project is built into the model and framework, but we wanted to capture the story here, too, so that we could detail that learning, underscore the process that got us to the model, and articulate clearly the driving values and vision of the Project.

## How YVSP Got Started

The Project grew out of ongoing conversations at the Boston Capacity Tank (BCT), a coalition of faith-based organizations, funders and community leaders that seeks to build the capacity of youth-serving organizations in Boston. Rev. Rocklyn Clarke—a Boston pastor and chair of the board of the Emmanuel Gospel Center (EGC), a BCT partner—began asking what we could do to understand the root causes of youth violence in our communities. His questions resonated with the group, and Klare Shaw suggested that the Barr Foundation—where she was at that time a Senior Advisor—might be interested in funding a project of this sort. Jeff Bass, EGC’s executive director, then agreed to begin to put together a project proposal to use system dynamics modeling for understanding youth violence in Boston from a community-based, systemic perspective.

The idea and the funding started to come together over the next several months, as did the passion and skills to carry it out. Khary Bridgewater had just come to EGC as the director of Applied Evaluation Systems (AES)—EGC’s consulting arm—and brought with him an existing desire to understand gang violence from a systems perspective. Paul Bothwell, who had been using systems thinking tools in the Boston community for some time, and Lynne Lyman, a political consultant and community advocate, joined the Project as strategic consultants. Steve Peterson, the model builder, joined in through prior connections with Mr. Bothwell and with the Barr Foundation. His personal commitment to make his services available at well below his usual market rate has been critical to the Project’s ongoing effectiveness.

“The thing that has drawn me to this Project is the sophistication of design in conjunction with the true process of community partnership that I believe will result in potential for change that’s greater than other programs I’ve seen in the past.”

—*Jack McDevitt, Project Advisor*

As the Steering Committee was formed, and other Project advisors and consultants were selected, it was clear that our goal was not to become “the experts” on youth violence in Boston. Instead, we wanted to work together with the communities most directly affected by youth violence to create this system dynamics model. The community would be the experts, and the model would then serve as a virtual laboratory to simulate youth violence intervention strategies in order to generate both better dialogue and better intervention strategies as gauged by the involved communities.

In Boston, violence is clustered in hotspot areas, so a few of these areas became the starting point of the Project. Rather than leaning only on outsider expertise, a favorite intervention strategy, or a particular philosophy of youth violence, the Project started with the idea that members of these most affected communities will understand youth violence the best. While we did also get input from a range of valuable outside perspectives, the community perspective was kept at the forefront throughout every step of the Project.

## The Underlying Assumptions of the Project

There are three main sets of assumptions that undergird the whole Project:

- Current youth violence interventions are hindered in their ability to collaborate because they lack a shared framework.
- The system dynamics approach can provide a suitable framework.
- The degree of true community involvement determines the value and success of the framework.

### *Youth Violence and Youth Violence Interventions*

Part of the backdrop of this work is the national data that has been gathered relating to youth violence. Youth violence—particularly gang violence—is a serious problem in most major U.S. cities.<sup>1</sup> Although levels of youth violence have declined since peaking in the mid-1990s,<sup>2</sup> the percentage of gun-related deaths has increased since 2000.<sup>3</sup> This increase has been particularly marked among young black men in recent years,<sup>4</sup> making homicide the leading cause of death for black males ages 10-24.<sup>5</sup>

Prevention-minded researchers have suggested that most initiatives to reduce youth violence operate mainly in isolation,<sup>6</sup> despite findings that cities which employ more coordinated efforts have lower rates of youth violence.<sup>7</sup> There are many youth violence task forces, but few include partners from outside of the criminal justice field. Some in the public health community have suggested the use of a multidisciplinary approach to engage health, justice, mental health, and education in addressing youth violence<sup>8,9</sup> but attempts at collaboration are hindered by the absence of a shared framework.

### *The System Dynamics Approach*

What does *system dynamics* even mean? System dynamics enables you to look at interrelated groups (think businesses, organizations, societies) or entrenched situations (such as poverty, health disparities, or in our case, youth violence) from a wide-angle perspective that can take in the whole of the many people, institutions, and organizations involved; their interactions and relationships; group structures; etc. (these are the **systems**) and

how all these things relate and change over time (these are the **dynamics**). From this perspective, we can see the way that the system is put together (its structure) and the patterns of dynamics that it exhibits over time (its behavior). Beyond just a new outlook, though, the system dynamics approach then allows us to use our *deeper understanding* to generate insight both about *improvement of* and about *communication around* a problem, issue, or challenge.

Youth violence is just the kind of complex issue where the system dynamics approach has potential to generate this kind of understanding, improvement, and communication. We would miss a lot if we focused only on one small aspect of the problem, but with this approach we were freed from having to *avoid* the complexities of youth violence. We were able to incorporate multiple voices from a variety of backgrounds in order to discern together the underlying structure and patterns of behavior of youth violence, to endeavor to coordinate intervention efforts, and to develop a shared language that allows us to communicate well with each other and with a broader audience about youth violence.

For greater detail on the system dynamics approach and an introduction to systems concepts, please see *The YVSP Strategy Lab*, Steve Peterson's article about the YVSP model.

### *Community-Based Participatory Process*

Community involvement is integral to the success of addressing any community-based problem. We knew that, given the opportunity, community members would have the ability to carry out every step of the process from problem definition to analysis to solution creation. We then wanted to build relationships where there was enough trust for all of us to work together. For YVSP, that meant starting from our existing relationships in the selected communities (through the Emmanuel Gospel Center, the Boston Capacity Tank, the High Risk Youth Network, and other partners) and then making new relationships with key community leaders, important neighborhood organizations, youth workers, families, gang members and other youth in the targeted neighborhoods. Taking our time and working through existing relational networks set up a Project that would both be acceptable to a range of community members and provide the required data for model building.

From the beginning we sought to establish credibility and ownership within the community so that this Project did not become another "outside-in" program. Community buy-in was essential to ensuring the long-term sustainability of the Project because residents repeatedly described incidents where researchers failed to respect the community's perspective due to race, class, and/or gender issues. This more sustainable approach, however, required a lengthy process in order to connect and build trusting relationships. We perceived this investment of time as being worthwhile in order to enable genuine collaboration in the model-building process.

As trust grew over the course of the Project, community residents became more open in sharing their unique, valuable insights into youth violence. In many cases residents had already devoted significant thought to the problem. We know that communities contain a diversity of perspectives, capacities, abilities, and levels of motivation. Through trusting relationships built around genuine respect and with thoughtful listening, we were able to

wade into the complexities of youth violence and find out the real understanding of people living in communities touched by this issue. We especially wanted the deep and meaningful insights that can be gained by understanding the opinions of youth. All in all, we knew that without community involvement we would run the risk of only creating more *misunderstanding* about youth violence.

## **Making the Idea a Reality: Funding, Overall Project Design, and Leadership**

### *Funding*

In June of 2007, we put together a concept paper for mapping youth violence in Boston and by October of that year there was a full project outline in place. In November, a proposal was submitted to the Barr Foundation that laid out the purpose of the Project as developing “a system dynamics model which reflects the best current thinking about youth violence in Boston” and made clear that this “best current thinking” would come from the minds of key community stakeholders.

The Barr Foundation became the major funder for the Project. Other significant funding partners joined in over the following months which are listed in full at the end of this article.

### *Overall Project Design*

From the beginning, the Project was conceived as an iterative, four-phase process. Each successive phase was intended to bring a deepening understanding of the system dynamics that would then be reflected in the increasing complexity and strength of the model. The first phase laid the groundwork; we conducted a review of academic literature and established the project plan. From this phase we had a basic model. During the second phase, we studied one high-violence neighborhood in Boston and convened a Design Team made up of community workers, residents and youth. We also assembled a “psych team” of psychology specialists to learn from their expertise. All of these Phase II contributors significantly enriched the model. During the third phase we expanded this process to include two more high-violence neighborhoods, and conducted listening sessions with gang members and leaders over the course of four months. Through each successive phase the model was improved to reflect the input of these many contributors.

Phase IV, which began in early 2010, emphasizes training youth workers, community leaders, youth, and many others on how to use the model to create effective conversations regarding how to reduce youth violence in our communities. We will continue to revise and improve the model based on what we learn throughout this phase, so that it can enable a variety of stakeholders to see how specific actions can affect the system of youth violence and what the likely results will be. We never expected to have “the solution” to youth violence at the end of this Project. We have, however, put into play a powerful tool that can have meaningful influence on many levels of intervention and help our communities and Boston leaders more broadly identify the highest leverage actions to take toward reducing youth violence.

### *Leadership: The Steering Committee*

The Steering Committee gathered for the first time in March of 2008, and there has been a group meeting monthly since then. It was a key decision of the Project to convene a multi-disciplinary team to shepherd the Project throughout and keep us focused on the community. The membership has changed somewhat during the Project, but it has always been comprised of representatives from AES/EGC, the model designer, researchers, various project supporters, and community liaisons. This team has also been supported by Organizational Partners and Project Advisors. Past and current Steering Committee members, Organizational Partners, and Project Advisors are listed at the end of this article.

## **Phase I: Literature Review and Groundwork for the YVSP Community Process**

After obtaining funding and gathering the Steering Committee, the Project was underway. The first phase of the Project ran from April to June of 2008, during which time we put together a literature review and laid the groundwork for the subsequent phases.

### *Literature Review*

We decided that a careful review of the academic literature was the appropriate first step for the Project, which allowed us to begin gathering perspectives from a broad spectrum of disciplines. The research team identified multiple theories in criminology, psychology, human development, and public health, and frameworks for how professionals and academics in those fields approach youth violence as a problem. These frameworks guide the goals and strategies in each field's programming and response to youth violence.

Like the Project as a whole, the literature review was conducted under the theoretical framework of systems theory. Because of that perspective, we were looking for understandings of violence that addressed four related systems related to any one person: the individual, the family, the community, and the larger culture/society. We then organized the information along these lines in the following way: general resources, the individual and violence, relational, community, and society. The literature review can be accessed online at: [http://www.gettingtotheroots.org/literature\\_review](http://www.gettingtotheroots.org/literature_review).

### *Groundwork for the YVSP Community Process*

After researching the broader literature, we began the local research process and chose to look at the issue of youth violence by neighborhood. Not every neighborhood in Boston is a high-violence one, so we assumed that there must be something particular to some neighborhoods that produced higher youth violence. Therefore we set out to understand the system dynamics in these particular neighborhoods. The broad literature review was a valuable starting point for general information, but we knew that for the specifics necessary to the system dynamics model, we needed the perspectives of neighborhood leaders, youth work practitioners, families, and youth.

Early on, the stage was set for a focused design process that would work both with and for the communities involved. The intent was always to create a resource that would belong to the community, and so we created a process to help residents capture their own knowl-

edge by participating in the design, execution, and evaluation of the Project. This approach was welcomed, with one participant declaring, “You’re asking me what I think creates the violence cycle? Now that’s a first. Usually outsiders come and tell us what they think, and then leave, and we never see them again!”

In Phase I, the parts of the process that would become Phases II and III were envisioned as first getting to know the selected neighborhoods and then convening Design Teams to oversee the development of the model.

## Phases II & III: Designing and Revising the Model

After the careful setup process of Phase I, the model-building process started and took place during Phases II and III of the Project. Phase II ran from July 2008 to March 2009, and Phase III ran from April 2009 to March 2010. The iterative process of these phases defies a chronological retelling, because Phase III was in many ways an expanded reprise of Phase II. It is easier to capture the learning of these two phases by grouping them and reviewing the four main threads of learning throughout:

- **Neighborhood Briefing Documents** were put together on each neighborhood. These documents provide the history, demographics and trends, assets (including schools, organizations, and faith communities), and public safety concerns for each neighborhood.
- **Design Teams** were convened from three of the original four selected neighborhoods: Uphams Corner, Bowdoin/Geneva, and Grove Hall.
- **Gang Member Listening Sessions** were conducted based on an anthropological approach to understanding the violent subculture of gangs and resulted in a deeper understanding of their distinct norms and behavioral codes.
- **Key Stakeholder Interviews and Specialist Groups** were held during both of these phases and introduced a broad range of perspectives on youth violence from police, the psychology team, youth workers, and mothers of killed youth.

### *Neighborhood Briefing Documents*

The Steering Committee chose four neighborhoods for focus: Uphams Corner, Grove Hall, Bowdoin/Geneva, and South End/Lower Roxbury. These specific neighborhoods were selected because they are areas where there is a higher concentration of youth violence. Calling a neighborhood a “hotspot” of violence, however, was one-dimensional at best. We knew that there was much more to be said about each of these neighborhoods, so the Steering Committee set out as our first task to learn more about the full picture of each neighborhood. In order to engage community residents with credibility, we needed to know what was generally known about each neighborhood. Our hope was that a well-done report would then also be valuable to community members (nothing like this existed previously) and would show we were serious about our relationship.

Each of the Neighborhood Briefing Documents is 40-60 pages long and provides history, demographics and trends, assets (including schools, organizations, and faith communities), and public safety concerns. These carefully researched documents contain:

- **History.** A roughly four-century overview of the area.
- **Boundaries.** Geographical outlines of these neighborhoods based on common understanding, US census tracts, the Boston Redevelopment Authority, and/or postal ZIP code.
- **Population trends/Racial and ethnic trends.** Growth and decline of the population, including specifics based on race and ethnicity (includes comparisons to state and national trends).
- **Age characteristics of the population.** Numbers and distribution of different age ranges, with particular focus on youth (includes comparisons to state and national trends).
- **Family structure.** Household size and structure, including living arrangements for children.
- **Economics and income.** Census information about poverty rates.
- **Housing.** Describes the housing stock, percentage of home ownership, and occupancy rates.
- **Churches, schools, and community organizations.** Detailed lists including contact information and maps.
- **Public Safety and Crime.** Boston police districts and youth arrest information.
- **Community Newspapers and media.** Lists newspapers, magazines, websites, and/or blogs dedicated to area.

A total of six Neighborhood Briefing Documents have been written. The first, Uphams Corner, was published in the spring of 2009. This one was followed by Grove Hall, Bowdoin/Geneva, and South End/Lower Roxbury in the summer of 2009. Since then two more studies were added in the summer of 2010: Greater Dudley and Morton/Norfolk. The research and publication resources of the Emmanuel Gospel Center (including the work of Senior Researcher, Rudy Mitchell) were used to create and then publish these documents for use by the YVSP collaborators and have also been made publicly available for anyone interested. These documents can be downloaded from: [www.egc.org/yvspbriefingdocs](http://www.egc.org/yvspbriefingdocs).

### *Design Teams*

During Phases II and III, Design Teams were convened from three of the selected neighborhoods: Uphams Corner (winter 2009), Bowdoin/Geneva (fall 2009), and Grove Hall (fall 2009). The Steering Committee had originally intended to convene a South End/Lower Roxbury Design Team as well but ultimately determined that this was not feasible.

Rather than having all three teams going at once, the Steering Committee chose to go through the whole process with the Uphams Corner team and then branch out to the Grove Hall and Bowdoin/Geneva teams. The benefit of this approach was the ability to debrief and then revise the process along the way. There was enough flexibility to be able to make changes if something was not working.

### *Who they were and what they did*

Each neighborhood Design Team consisted of 12 representatives—six adults and six youth—drawn from three partner organizations in each area. The partner organizations were chosen for their history of work in youth violence and respected status as commu-

nity-led agencies. The selected agencies appointed their own representatives (one agency worker, one adult community resident, and two youth community residents).

Once assembled, the teams were led through a collaborative learning process focused on building trust and a spirit of inquiry where participants openly challenged assumptions, experimented with ideas, reflected publicly about the project design, and—of course—dug deeper for insights related to the dynamics of youth violence.

The work of these teams was to oversee and approve the development of the model framework and the core logic of the model. That is, they were to work together to reflect deeply on how violence was happening right then as well as uncovering trends of how it has happened over time. They each made specific contributions to the development of the model both in the theoretical framework and the model mechanics. For an example, see the “slippery slope” map shown later in this article and also in Steve Peterson’s “The YVSP Strategy Lab.”

Bird Street Community Center  
Dorchester Bay Economic Development Corporation  
Dudley Street Neighborhood Initiative

#### **UPHAMS CORNER**

The Design Team from Uphams Corner was the first to begin shaping the computer model in the late fall of 2008 and into the

winter of 2009. The team met five times. They started with training around system dynamics and went on to conversations about the culture of violence and other big picture ideas like community trauma. They discussed the role of public institutions and the ways these institutions are hindered in carrying out their purposes such as lack of resources, inappropriate policies, and/or cultural biases. They analyzed the movement of youth through the various “buckets,” introduced the ideas of association and apprenticeship, and clarified the differences among more- and less-organized gangs.

Bowdoin Street Health Center  
College Bound Dorchester  
Catholic Charities Teen Center at St. Peter’s

#### **BOWDOIN/GENEVA**

The Design Team from Bowdoin/Geneva met four times during the fall of 2009. They did not create the original version of the model

and were skeptical at first about some aspects of the framework. Over time they came to accept major aspects of the model while altering others. This team discussed in depth how youth become involved in gangs. They also called for a longer list of interventions, and they introduced a new “rogue” bucket to account for violence carried out by youth not involved in a gang (perhaps motivated by revenge). They also drew attention to an individual’s context, noting the importance of where and with whom someone grows up in determining their later involvement in violence.

Charles Street AME Church  
Freedom House, Inc.  
Project RIGHT

“Being on the Design Team showed me that I had a different role than I thought I had. It’s kind of major to be on a Design Team like this that’s going to help the entire city. It kind of boosted my self-esteem as a youth in the community that I can have hands-on contact with something that’s going to change the community.”

—Grove Hall Design Team Member, youth

## GROVE HALL

The Grove Hall Design Team met four times in the fall of 2009. Like the team from Bowdoin/Geneva, they were continuing the work started by the Uphams Corner team. This team did a lot of work on how young people move into gangs, how they decide to become violent, and especially the impact of family and community on youth. This group broadened the conversation beyond youth violence to include other issues, needs, and strengths of their community. They also confirmed the basic flows of movement of youth into gang involvement and violence.

### *Our Learning about Design Teams*

Even as the model was being worked on by the Design Teams, the YVSP team was learning how best to facilitate that process. Here are some examples of our overall thinking on the Design Team process, which in some instances was refined along the way as the work was unfolding:

- **The visual language of diagrams.** Some of the systems jargon could be too dry and abstract, so we shifted to the visual language of diagrams (e.g. the Slippery Slope map) that gave us a simple, shared way of talking about a complicated system. As these diagrams were refined, they became the visual log of the Design Teams’ decisions and analysis.
- **Reducing what could get “lost in translation.”** By the time the second and third Design Teams were meeting, we saw the wisdom of having the model builder (Steve Peterson) present at those meetings so that the extra step of reporting back to him was removed from the process.
- **Asking “how?”** It is tempting to focus on the “why” of youth violence and gang involvement. The Design Teams worked on creating a model of what involvement is and *how* it happens.
- **Hiring of consultants.** Design Team members—including youth—were paid workers, not volunteers.
- **Different groups, different approaches.** Each group had a distinct feel. We didn’t want to have a “one size fits all” approach to the teams, and we were free to let them shape themselves and to be responsive to what approach worked best for the people in the room.
- **Listening to youth.** We listened to the youth and included their views because they were full partners in the design process. We did not invite them in as “junior partners” to witness the adult conversation.
- **The team had passion, too.** We did not come in as flat, objective outsiders. Khary Bridgewater led the way in bringing in personal passion to the research process and sharing this passion openly with the Design Team members.

## *Gang Member Listening Sessions*

As described above, the community members on these Design Teams made significant contributions to the model and its framework of understanding youth violence. That said, these same community members also expressed reservations because they actually knew little of the inner workings of gangs or the behavior and motivations of gang members. We therefore determined to seek the participation of both active and former gang members in understanding and addressing youth violence.

We started by holding two focus groups with gang violence experts to create a safe, effective way of engaging gang members. From the input of these groups came two key strategies that shaped the overall approach to what became the listening sessions:

- **Go deep and ask for details.** Rather than asking about general information on gang violence, we asked for detailed information about their personal experiences related to gang violence.
- **Take your time and meet as a group.** Rather than meeting one-on-one, we hosted group sessions where we could take our time and allow for the opportunity to build trust and gain a deeper understanding regarding these personal experiences about which we were asking.

Taken together, these strategies led to a direct, interpersonal approach to the inquiry process.

The actual listening sessions were held in the summer of 2009. There were four sessions for younger, active members and one for older, former gang members. It seemed natural to separate the two groups given the distinctions in both their current and past experiences implied by the age and status differences. We assumed that all of these participants, while part of this semi-isolated subculture, would still care about reducing youth violence in their neighborhoods. It is important to note that, as with all other Project designers, they were compensated for their time.

These gang members contributed significantly to the development of the model, and it seemed that the time spent carefully listening to their personal experiences was very valuable. They helped refine the assumptions underlying the model and framework and clarify the movement of young people along the slippery slope.

Khary Bridgewater has described his personal experiences during this research process and detailed findings from it in *The Reason Why We Haven't Solved the Gang Violence Problem*. Here is a brief overview of the findings:

- Increasing violence is driven by dramatic increases in gang members.
- Traumatic stress is changing the way violent and nonviolent youth behave.
- Gang violence is addictive.
- There are significant unintended consequences of suppression strategies.
- Gangs represent a significant alternative social system.

## *Additional Stakeholder Interviews and Specialist Groups*

In addition to the research done through the creation of the Neighborhood Briefing Documents, the work of the Design Teams, and the listening sessions with gang members, we also conducted several interviews with additional key stakeholders and convened two specialist groups.

### *Stakeholder Interviews*

These interviews were conducted with key stakeholders who have both an “inside” and big picture view on youth violence in Boston. Here is a brief synthesis of what we learned from these sources:

- **Police representatives** commented on their lack of a diversity of tools for responding to youth violence (basically incarceration or the threat of it). They noted generally the influence of the bad economy leading to lack of jobs leading to illegal means of getting money.
- **Courtney Grey**, director of trauma services at the Boston Public Health Commission, introduced a foundational concept to the model through the idea of community trauma. He contributed the understanding that collective community trauma influences individual responses to stimuli.
- **Emmanuel Tikili**, at that time Director of Programs for the Boston TenPoint Coalition, brought in an understanding of the dynamics within a community where there is certainly tension between gangs but also among various residents and youth in general.

### *Specialist Groups*

#### **Psychology Team**

The psych team contributed a great many concepts to the model. Here are some of their key influencing ideas:

- Natural limits to adolescent cognitive development may explain some violent behavior (e.g. difficulty in seeing consequences).
- The notion of a personal predisposition toward or away from violence.
- Various motives for violence like self-defense, retaliation, compliance with behavioral norms of gangs, thrill-seeking, transference of past hurts, operating from “survival mode,” etc.
- High trauma exposure leading to PTSD-type behaviors such as physiological hyper-arousal and avoidance.

#### **Tina Chery’s Mothers Group**

In February of 2009, Tina Chery, founder of the Louis D. Brown Peace Institute, hosted a group of about ten mothers whose children were killed in gang-related violence. They, too, contributed many concepts to the model. Here are some themes that emerged from this group:

- Parents have a powerful voice in their children’s lives
- There have been marked changes in access to and use of guns in recent years

- Violence seems to be carried out without any feeling or attention toward long-term repercussions
- There is a general awareness of the lack of grief services and other important community supports for those who have lost loved ones to violence

## The YVSP Model

The YVSP Strategy Lab—or “the model,” as everybody refers to it—is where all these many contributions came together. It reflects the thinking of the Design Teams, the specialist groups, gang members, and the other key stakeholders along with the background research to give us a computer simulation that captures key interdependencies in the dynamics of youth violence in Boston communities. The design process included many major and minor revisions of the model, and it is still being updated and strengthened to better represent reality.

### Overview

The model is driven by the interaction of five key components: slippery slope dynamics, high-risk interactions, community trauma, affinity for violence, and youth violence.

What you see here is that slippery slope dynamics (explained below) among youth provide the context in which high-risk interactions occur. As suggested by the name, high-risk interactions are those interactions among individuals and groups within the community, that have the potential to result in violent activity. Violence, in turn, can cause the buildup of symptoms of trauma for some members of the community, which then increases the likelihood of high-risk interactions among certain youth. Finally, among those engaged in violence, violent acts can drive the buildup of an affinity for violence as the default mode of interaction, further driving violent activity over time.

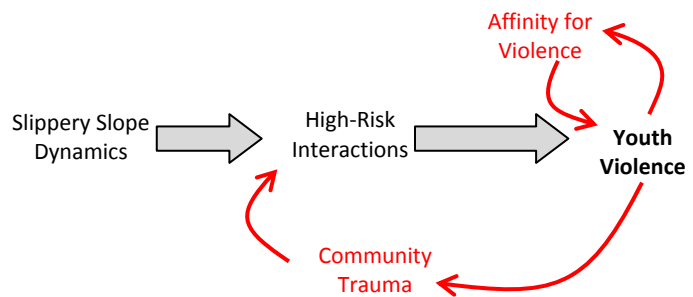
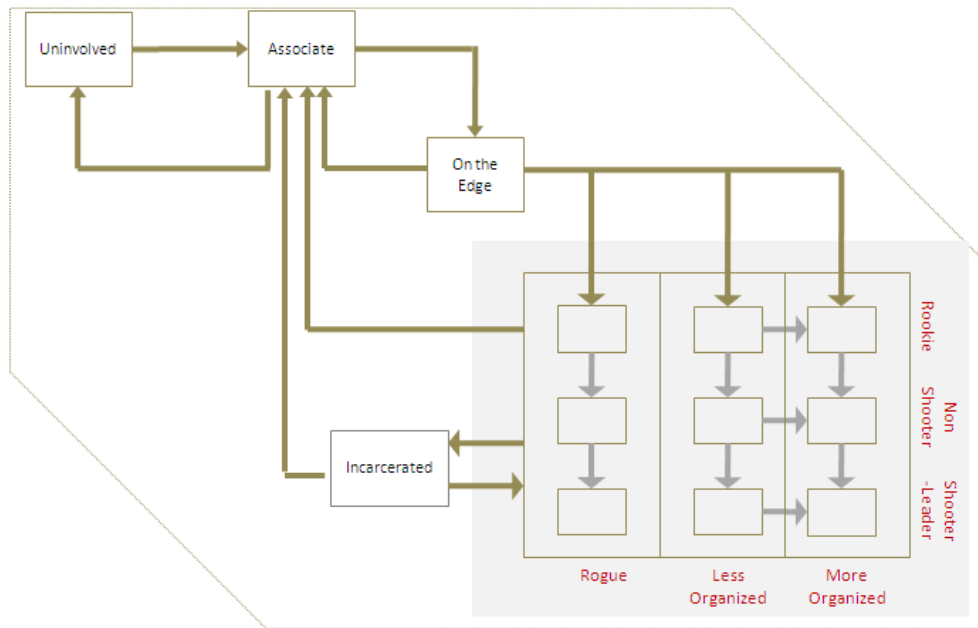

Figure 1. Overview of the YVSP Strategy Lab

### Slippery Slope Dynamics

The slippery slope map (shown on next page) was developed over multiple Design Team meetings. It is a fundamental organizing framework for the model. The stocks—or “buckets”—shown as rectangular boxes in the map categorize youth along the spectrum from “Uninvolved” to “Gang Shooter/Leader.” The flows, indicated by directed arrows, represent pathways by which youth can move over time between the different buckets. Overall, the slippery slope enables us to capture the potential for youth within a defined community to drift over time toward gang involvement.



**Figure 2. The “Slippery Slope”**

### *High-Risk Interactions*

Slippery slope dynamics create the context in which high-risk interactions take place. In any community there is a network of potential connections between individuals and groups. Over time, interactions occur along these lines of connection. The further down the slippery slope, the riskier these interactions are in their potential for violent activity.

### *Community Trauma*

Referring back to the first diagram (figure 1), you see “slippery slope dynamics” creating the context for “high-risk interactions” which increase the likelihood of youth violence. Above and below are two other components that are shown in feedback loops with the others. Community trauma is the first of these.

Many high-violence communities tend to exhibit symptoms of post-traumatic stress (like a persistent fearfulness and watchfulness). For some, these symptoms can cloud the way they read a particular situation, turning a benign interaction into one that has potential for violence. A feedback loop then gets created where the heightened level of community trauma leads into a higher likelihood for high-risk interactions, which in turn results in more violence and more trauma.

### *Affinity for Violence*

The second feedback loop in the overview diagram (figure 1) links in “affinity for violence.” Here is a slightly more detailed feedback loop to explain this component of the model. The loop says that the more one engages in violence, the more violence becomes the “default” operating mode for interacting

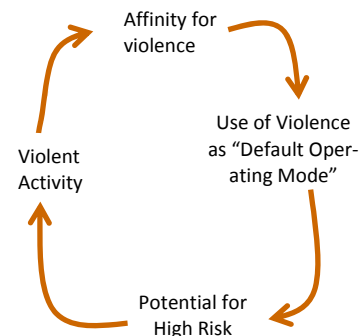

**Figure 3. Affinity for violence**

with others. This, in turn, further fuels the cycle for those who choose to engage in violent activity.

### *Youth Violence: Tying it all together*

Slippery slope dynamics, high-risk interactions, community trauma, and affinity for violence all come together in the generation of youth violence. The model and its accompanying framework can help individual and group exploration of initiatives aimed at changing the rates of movement of individuals along the slippery slope, as well as initiatives aimed at changing the nature of social interaction within the community.

"I am now able to see, understand and explain where my organization fits in with other initiatives and organizations to reduce youth violence."

—Tina Chery, meeting August 2010

If you are curious to know more about the model, Steve Peterson (who created the computer simulation) has described it in much fuller detail in an article called *The YVSP Strategy Lab*. He gives a thorough walkthrough of the model along with an introduction to systems.

### **What We Are Learning**

Our goals for this phase are to broaden the base of users of the model, create a broader conversation about youth violence, help people see where they fit into the framework, discern what is missing, and increase the dialogue about what strategies are needed. We do not need to defend the model as it stands or teach it as an end result. Rather, we need to continue the conversations which allow it to be deliberately refined in order to reflect reality better and be an increasingly useful tool.

People are using the model, and its power to provide a shared framework of understanding and a shared language for communication about youth violence is becoming clearer and clearer. Organizations are not only gaining a deeper understanding of how their own work serves to reduce youth violence, but they can easily appreciate the approach taken by another group from their own or a different neighborhood when it's demonstrated through the model and talked about in its now-familiar terms. These groups can then celebrate the value of their combined efforts and take a larger, systemic view that shows how they can partner together to serve youth better as well as communicate more broadly about what works for their communities.

Since the model was launched, a wide range of people have interacted with it in a variety of settings. Here are some of the places the model is being put to use for collaborative learning:

- **Youth Worker and Agency Trainings.** YVSP is providing training on the model and framework to any interested agencies. neXus Boston is also hosting a Learning Center for youth workers as an expression of its existing work as a learning community.

- **Learning Centers.** Some of the organizations that have been partners throughout the Project are now hosting Learning Centers: Catholic Charities Teen Center at St. Peter's, Dudley Street Neighborhood Initiative, and Project RIGHT.
- **Community Forum.** The YVSP Community Forum took place in December 2010. The centerpiece of that evening was presentations from the three learning centers (listed above), from one youth worker connected through neXus (Joel Furrow, Bridging the Gap), and from a representative of a partner agency (Tina Chery, Louis D. Brown Peace Institute).

We are seeing the payoff of all the design work now as people are better able to communicate effectively about youth violence and work together toward improving all our neighborhoods. The more the model is used and refined, the more the momentum builds for it to be an effective framework and tool for dialog, collaborative decision making, and thoughtful action.

This Project has been characterized by a thoughtful, deliberate process, and this phase will be no different. We are aware of the potential of this tool to inform a community-centered process and empower community members to strategize about ways to achieve a long-term reduction in violence. On the other hand, it could be taken and misused in an ultimately divisive and counterproductive way. We will therefore keep to the same types of thoughtful processes we've used all along to accomplish the purpose of sharing the model more broadly so that its essential orientation toward learning, sharing, and collaboration is not lost.

For more detail (and more stories and photos) on who is using the model and for what purposes, see *What We Are Learning*. If you are interested in receiving training, please see the contact information listed at the end of this article.

## Reflections on the YVSP Process

The combination of a community-based research process and system dynamics methodology has led to a model of youth violence that is increasingly able to serve its intended purpose of providing a shared language and shared framework of understanding around youth violence.

The value of the Project has been the collaborative learning process through which the partner organizations, community members, youth, and the Steering Committee have gone together. What follows are some reflections on the essential takeaways of this process:

- **Successful partnership requires considerable effort.** We included a range of partners—youth, community members, agency representatives, and gang members—in the development of the Model, all as co-researchers. This process took twice as long as originally planned, but this type of partnership is more satisfying all around, especially for groups who often serve as a source of information for academic research but are seldom included in what information is analyzed or presented.

- **Yes, the community can do systems thinking.** Community members—particularly youth—readily take to the systems approach and the computer simulation. Many people have a strong intuition for interdependencies and the sense of “everything is connected to everything else.” The model and framework put language to this existing understanding and fosters the empowerment to make lasting changes.
- **Going deeper with gang members helped us to begin to understand the subculture.** We consistently put the understanding of community members first in the research process. When these community members, however, pointed to gaps in their understanding of what really happen within gangs, we approached gang members directly. The resulting very direct, interpersonal approach for the gang member listening sessions enabled us to begin to understand the rules, norms, behaviors, and motivations of gang members and led to the perception of a subculture with fundamentally different behavioral norms.
- **People are thinking and talking together from different neighborhoods, disciplines, ages, and backgrounds.** This Project was envisioned as a tool for creating a shared framework of understanding around youth violence that would be meaningful to a wide range of people from different fields who are all working to reduce youth violence. It is encouraging to see that already happening through the creation of Learning Centers and the kind of large group conversation that happened at the Community Forum.
- **People understand their own neighborhoods in a deeper way.** Alongside this thinking and talking together across neighborhoods was a profound experience of understanding within each neighborhood. The framework and shared language allowed each neighborhood to speak of and reflect on its unique, local experience of violence and how that works *without* having to generalize across neighborhoods. That opportunity added more integrity, deeper reflection, and better insight into the conversation and removed the element of judging “those people over there.” Each team knew that their unique insights would be represented in the model along with the unique insights from people in other areas.

## Summary

YVSP employed a community-based participatory research process in which community residents participated in the design, execution, and evaluation of a detailed, system dynamics computer model of youth violence in Boston. These residents, from agency leaders to youth to gang members, provided unique insights into the behavior of violent youth in Boston. Their empowerment and engagement in a community-driven process fostered a collaborative environment in which the logic of community residents could be articulated and explored. The group model-building process created enthusiasm from community residents as they saw their own logic reflected in the evaluation of violence-reducing initiatives.

We are excited about the model that has been created, but we are perhaps more excited about the collaborative learning that has taken place throughout the process of listening

to the many voices and many perspectives that give the model its value. This effort took time, commitment, and the efforts of many people to bring it to fruition. It was worth it. The model is a powerful tool when applied to the neighborhoods from which it was generated. For those who would want to carry out similar work in another locale, it is the *process* that would need to be imported, not the model.

Going forward we are excited to broaden the base of users of the model while preserving the core values of the Project to date. To that end, we will continue putting the community first and allowing the basic neutrality of the framework to provide us with a way into deeper understanding and better communication so that we can take thoughtful action toward reducing youth violence in our city.

---

<sup>1</sup> Weiss B. An Assessment of Youth Violence Prevention Activities in USA Cities. Los Angeles, CA: Southern California Injury Prevention Research Center UCLA School of Public Health; 2008.

<sup>2</sup> Elliot D, Hatot NJ, Sirovatka P, eds. Youth Violence: A Report of the Surgeon General. Washington, DC: Department of Health and Human Services, 2001.

<sup>3</sup> Fox J, Swatt A, Swatt M. The Recent Surge in Homicides involving Young Black Males and Guns: Time to Reinvest in Prevention and Crime Control. Boston, MA: Northeastern University; Dec. 2008.

<sup>4</sup> Fox J. *Ibid.*

<sup>5</sup> Web-based Injury Statistics Query and Reporting System (WISQARS). *Ibid.*

<sup>6</sup> Cohen L, Davis R, Franchak S, Prothrow-Stith D, Quaday S, Swift S, Uchishiba N. Shifting The Focus: An Interdisciplinary Framework For Advancing Violence Prevention. Prevention Institute Web site. <http://www.thrive.preventioninstitute.org/shifting.html> Updated 27 July 2006. Accessed 6 Jan. 2010.

<sup>7</sup> Weiss B. *Ibid.*

<sup>8</sup> Cohen L. *Ibid.*

<sup>9</sup> Cook P, Laub J. The Unprecedented Epidemic in Youth Violence. *Crime and Justice*. 1998; 24:27-64.

## Steering Committee, Advisors, Partners, and Funders

### *Steering Committee*

The Steering Committee has provided oversight and maintained the Project's community focus throughout.

Jeff Bass*	Tamecia Jones	Rudy Mitchell
Paul Bothwell*	Sam Kim*	Steve Peterson*
Khary Bridgewater*	Myra Kinds*	Talia Rivera
Matthew Gibson*	Jin Min Lee*	LeSette Wright*

*\*denotes current members*

### *Project Advisors*

The Advisory Team consists of leading scholars and practitioners in the youth violence prevention field who inform the underlying strategy and approach of the YVSP and regularly advise the project team.

Rev. Dean Borgman  
Gordon-Conwell Theological Seminary,  
Charles E. Culpeper Professor of Youth Ministries, 1976

Rev. Jeffrey Brown  
Executive Director of Boston TenPoint Coalition

Rev. Dr. Ray Hammond  
Chair and Founder of the Boston TenPoint Coalition

Dr. Jack McDevitt  
Northeastern University, Associate Dean for Research and Graduate Studies in the  
College of Criminal Justice  
Director of the Center for Criminal Justice Policy Research  
Director of the Institute on Race and Justice

### *Organizational Partners*

Emmanuel Gospel Center  
Black Ministerial Alliance of Greater Boston  
Boston Capacity Tank  
Boston TenPoint Coalition  
High Risk Youth Network  
United Way of Massachusetts Bay and Merrimack Valley

## *Community Partners*

Bird Street Community Center  
Bowdoin Street Health Center  
Catholic Charities Teen Center at St. Peter's  
Charles Street AME Church  
College Bound Dorchester  
Dorchester Bay Economic Development Corporation  
Dudley Street Neighborhood Initiative  
Freedom House  
Project RIGHT

## *Funders*

Barr Foundation  
Charles H. Pearson Foundation Fund, Bank of America, Trustee  
Florian O. Bartlett Trust, Bank of America, Trustee  
Frank Reed & Margaret Jane Peters Memorial Fund I, Bank of America, Trustee  
State Street Foundation  
United Way of Massachusetts Bay and Merrimack Valley  
Yawkey Foundation II

## **Further Reading/List of Publications**

### *Related Articles*

There are three partner articles to this one. Each was written to provide a depth of detail on particular aspects of YVSP that complement corresponding shorter sections of this article.

- The YVSP Strategy Lab describes YVSP's system dynamics model in detail, including an introduction to the key systems concepts for understanding the model.
- The Reason Why We Haven't Solved the Gang Violence Problem discusses how the YVSP team solicited the input of gang members in the design process, and describes the findings and insights gained.
- What We Are Learning describes how the model is being used in various settings, and what different folks are learning from the discourse so far.

### *Literature Review*

Our research team compiled a survey of academic studies, reports and other resources on youth violence from disciplines as far-ranging as sociology, criminology, public health, psychology and economics. The over 200 sources listed are only a part of the background research conducted for this project to determine what is publicly known about youth violence and how academics are interpreting that information. Available at: [www.gettingtotheroots.org/literature\\_review](http://www.gettingtotheroots.org/literature_review).

### *Neighborhood Briefing Documents*

Since the project began in the spring of 2008, we have published six neighborhood briefing documents that provide history, demographics and trends, assets (including schools,

organizations, and faith communities) and public safety concerns. Here is the list of Neighborhood Briefing Documents:

- Uphams Corner
- Bowdoin/Geneva
- Grove Hall
- South End/Lower Roxbury
- Greater Dudley
- Morton/Norfolk

Available at: [www.egc.org/yvspbriefingdocs](http://www.egc.org/yvspbriefingdocs)

### *Journal Article*

In spring 2011 an article entitled “A Community-Based Systems Learning Approach to Understanding Youth Violence in Boston” will be published in *Progress in Community Health Partnership: Research, Education and Action* about YVSP. It describes the work of YVSP for an academic and public health audience and was written by:

- Khary Bridgewater, Emmanuel Gospel Center
- Steve Peterson, Lexidyne, LLC
- John McDevitt, Ph.D., Northeastern University College of Criminal Justice
- David Hemenway, Ph.D., Harvard School of Public Health
- Jeffrey Bass, Emmanuel Gospel Center
- Paul Bothwell, Dudley Street Neighborhood Initiative
- Ros Everdell, Dudley Street Neighborhood Initiative

### **For More Information**

#### *General Information*

Sam Kim  
Emmanuel Gospel Center  
2 San Juan St., P.O. Box 180245  
Boston, MA 02118  
Tel: 617-262-4567  
Cell: 617-529-3459  
Email: [skim@egc.org](mailto:skim@egc.org)  
[www.gettingtotheroots.org](http://www.gettingtotheroots.org)

#### *To Schedule Trainings:*

Jin Min Lee  
Emmanuel Gospel Center  
2 San Juan St., P.O. Box 180245  
Boston, MA 02118  
Tel: 617-262-4567  
Email: [jlee@egc.org](mailto:jlee@egc.org)  
[www.gettingtotheroots.org](http://www.gettingtotheroots.org)



## THE YVSP STRATEGY LAB

Steve Peterson

The Youth Violence Systems Project (YVSP) was initiated to empower the community's perspective on youth violence in Boston by creating a framework for developing intervention strategies that lead to real change. Since 2008, YVSP has been using a community-based approach coupled with systems dynamics modeling to create a virtual laboratory to model youth violence intervention strategies. Our goal is to help develop the capacity for deep and honest dialogue among a wide range of people to collaborate toward a shared goal of reducing youth violence in our neighborhoods.

This article describes YVSP's system dynamics model in detail, including an introduction to the key systems concepts for understanding the model. In addition, the story of the YVSP process is further told in three related articles:

- **The Youth Violence Systems Project: A Community-Based Framework of Understanding Youth Violence in Boston** gives an overview of the community-based process that is at the heart of YVSP. It also gives a brief introduction to the content covered in more depth in the other three articles.
- **The Reason Why We Haven't Solved the Gang Violence Problem** discusses how the YVSP team solicited the input of gang members in the design process, and describes the findings and insights gained.
- **What We Are Learning** describes how the model is being used in various settings, and what different folks are learning from the discourse so far.

### You're going to build a what?

The YVSP Strategy Lab is a computer simulation model that captures key interdependencies that underwrite violence among youth in Boston communities. It represents a significant investment of time, energy, and expertise over a long period of time. Yet, if you're thinking about youth violence, it is probably the case that a dynamic model is not the first thing that will come to mind. Why bother building a simulation of youth violence? What's the benefit of developing and using a computer simulation?

As it turns out, there are two important sets of reasons for building this model. The first set of reasons relates to the nature of the problem itself. The second relates to the community process that can be supported through development of the model.

### *Youth Violence is a Systems Problem*

Youth violence is a pernicious problem that faces many large US cities. Within the US, for example, homicide is the leading cause of death for African American males aged 10-24. This problem is very difficult to unpack, understand, and ameliorate using traditional

tools and processes. In high-violence communities, the problem has stubbornly resisted efforts aimed at improving the situation.

Part of the challenge here is that youth violence is a *systems problem*. Systems problems are inherently challenging, primarily because of their essential characteristics [see sidebar]. Like other systems problems (you might take a moment to consider your favorite pressing issue or concern), youth violence involves dynamic relationships that change over time. Just as it is challenging to herd cats, it can be challenging to get a dynamic system to perform as desired. Underneath the dynamics, you see multiple players, driven by diverse interests. It's difficult to gauge the relative strength of the interdependencies that drive behavior or the unintended consequences that can get set into motion as result of an initiative. And it can be hugely difficult to communicate understanding in simple ways that regular folk can understand. Tools and frameworks that were designed to address simpler problems may not be up to the task of tackling a systems problem.

## Key Characteristics of a Systems Problem

1. Dynamics—change over time
2. Multiple Players, diverse interests
3. Driven by interdependencies
4. Very difficult to communicate

That's where *system dynamics*, the approach that we have used in this Project, can add value. System dynamics has evolved over the past 50 years, and is currently being applied to a broad swath of issues in the private and the public sector. As outlined in the next section, it provides an approach for building understanding around systems problems, and for testing initiatives aimed at improving performance. Because system dynamics relies on a simple, graphical language, it's accessible to wide range of individuals. Because sophisticated math is going on under the surface, a system dynamics model can bring some of the tools of the hard sciences to messy social problems.

## *A Model Can Support a Community-Based Process*

While it's possible to do system dynamics analyses in the back room or the ivory tower, for our project, the real value of building and working with a model is that it has become a focal point for engaging a broad set of community perspectives in the process of thinking rigorously about a pressing social issue. The resultant learning and insight is something that stays with the community.

Because the objective of this project is fundamentally about empowering the community to understand community-based violence and to strategize ways to achieve sustained reductions in violence, we felt that the modeling approach could provide significant value-added. The modeling effort became an instrument for engaging the community in productive dialogue. In developing the model, for example, we relied heavily on the youth insight into gang involvement. Central to this process was a set of design team meetings, in which adults and youths with first-hand knowledge shaped the development of the model. The discussions that shaped model development worked to build community and to forge a common understanding among participants. Subsequent work has provided multiple opportunities for teams of individuals to interact with the model, but perhaps more important, to interact with one another in focused, thoughtful conversations about experiments, outputs, and the relation of the model to their world. Through this process,

the model has helped to focus, capture, and advance community thinking around youth violence.

## A Really Brief Introduction to Systems

In order to understand the inner workings of the YVSP Strategy Lab, it's important to have just a bit of an understanding of the key concepts associated with the system dynamics modeling approach from which the model was developed. Here, we'll provide a quick overview. Books (heavy books!) have been written on the subject, so if you want to dig deeper, a quick on-line search will speed you on your way.

### *Systems Concept 1: Structure drives behavior*

Doug Hall of EGC likes to talk about the differences between a cat and a toaster. One important difference is that while a cat is structured to do cat-like things, a toaster is structured to make toast. This insight is the heart of the idea that structure drives behavior. The implication of this concept is simple: If you understand how a process or system is put together, you'll be in a better position to design interventions aimed at improving the performance of the system.

### *Systems Concept 2: Stocks and flows*

Stocks and flows provide a mechanism for representing the essential structure of a system. Stocks, represented by a rectangle, are accumulations. You can think of them as buckets that hold various forms of stuff—people, things, money, etc. Flows, represented by directed pipes, represent the actions or activities that cause stocks to fill or drain over time. The simple examples below illustrate the dynamics that emerge from a simple stock and flow structure. A more complex structure, such as the “slippery slope” that emerged from discussions with community members, is capable of underwriting extremely sophisticated dynamics.

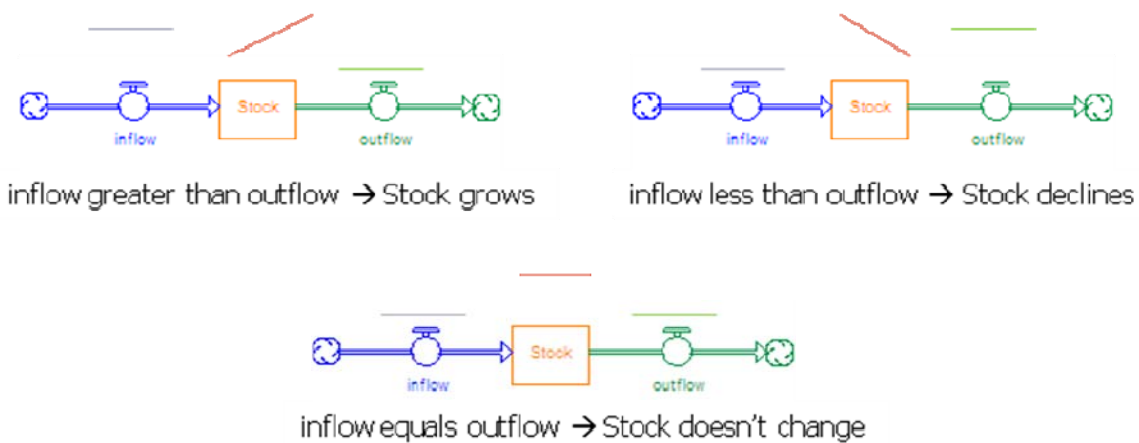

**Figure 1. Simple Examples of Structure-Behavior Pairings**

### *Systems Concept 3: Nonlinearities*

Many familiar systems are linear in the sense that output is proportional to input. For example, if it takes you five minutes to walk a certain distance, you're likely to walk twice that distance in ten minutes. In contrast, more complex systems often are nonlinear in nature. A change in one part of the system can lead to disproportionately large (or small) changes elsewhere in the system. As you'll see, the YVSP Strategy Lab incorporates several important nonlinearities that emerge from the underlying structure of high-violence communities.

### *Systems Concept 4: Feedback*

Feedback is at the source of many system nonlinearities. If you've ever seen your favorite sports team go on a "run," you've seen the effect of feedback. Your team scores. Their confidence grows. They find it easier to score again. Confidence grows even more! More formally, feedback exists when the current state of the system along one or more dimensions motivates actions, which in turn change the state of the system as you move forward in time. This is illustrated with the simple feedback loop diagram in Figure 2.



**Figure 2. A simple feedback loop**

Feedback processes underwrite many real-world dynamics of growth, decline, and equilibrium seeking. In the YVSP Strategy Lab, feedback is at the heart of two critical processes that can cause a community to get "stuck" in high-violence cycles.

### *Systems Concept 5: Don't seek to prove truth; seek to falsify*

Falsification has a long history in the philosophy of science. This approach to building understanding involves the development of a provisional explanation for why something is happening, and then testing that explanation to discover the circumstances under which it doesn't hold together. The learning cycle continues as new insights are incorporated into an improved explanation. Our work on the YVSP Strategy Lab has given us multiple opportunities to test our thinking in this manner. In particular, our interaction with engaged communities of interest (especially the adults and youth members of Design Teams) provided us with opportunities to gain "ground truth" insight into high-violence communities. This insight from team members then was used to improve the inner workings of the simulator.

## **How the YVSP Strategy Lab Works**

In the creation of the YVSP Strategy Lab, we have worked very hard to develop a highly physical, value-neutral representation of the relationships that drive violence among youth. The model is physical, in the sense that it uses stocks and flows to account for changes in the composition of a community's youth population over time. It is value-neutral, in the sense that it provides a framework for exploring policy initiatives from a

wide range of sociopolitical perspectives. The model is driven by the interaction of five key components, as illustrated to the right.

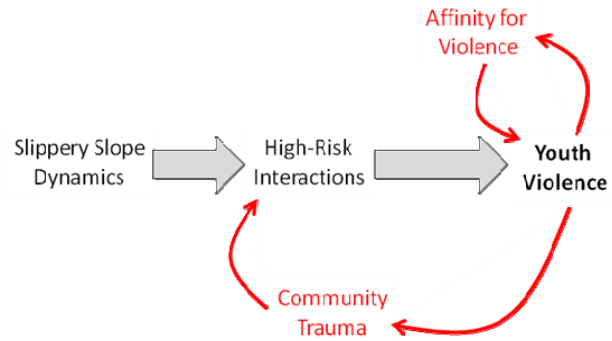

**Figure 3. An Overview of the YVSP Strategy Lab**

In the model, slippery slope dynamics among youth provide the context in which high-potential-for-violence interactions occur. As suggested by the name, high-risk interactions are those interactions among individuals and groups within the community, that have the potential to result in violent activity. Violence, in turn, can cause the buildup of symptoms of trauma within the community, which in turn increases the likelihood of high-risk interactions among youth. Finally, among those engaged in violence, violent acts can drive the buildup of an affinity for violence as the default mode of interaction, further driving violent activity over time.

Let’s take a closer look at these key components of the YVSP Strategy Lab.

### *Slippery Slope Dynamics*

The slippery slope map (shown below) was developed over multiple Design Team meetings. It continues to be refined as we engage with communities of interest. The “buckets” in the map categorize youth along the spectrum from “Uninvolved” to “Gang Shooter/Leader.” The flows, indicated by directed arrows, represent pathways by which youth can move over time between the different buckets. Overall, the slippery slope enables us to capture the potential for youth within a defined community to drift over time toward gang involvement.

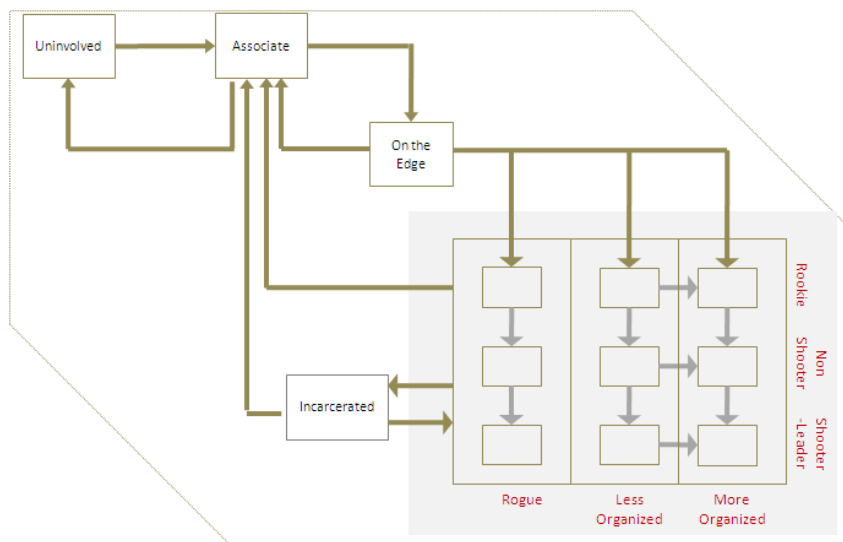

**Figure 4. The "Slippery Slope"**

As a fundamental organizing framework for the YVSP Strategy Lab, the slippery slope map serves the overall project in several important ways. First, it provides one vehicle for understanding differences between communities—higher violence communities are more likely to have higher concentrations of gang members than lower violence communities. Second, the map has enabled us to elicit deep insights from community members. Initially, for example, we began with a very simple representation of gang members: a single bucket. By discussing this simpler structure with community members, we learned about the differences between Rogues (isolated individuals), Less Organized Gangs, and More Organized Gangs (often organized more or less as a small business). Similarly, we learned about the development path for gang members (Rookie to Non Shooter to Shooter/Leader) through discussions around a simpler structure. Third, the map provides a way for individuals, agencies, and other interested parties to identify the targets for various initiatives. A summer youth jobs program, for example, might be targeted at moving youth back from “On the Edge” status. Finally, because the slippery slope map enables us to characterize the rate of movement of youth as well as the distribution of youth among the various buckets at any point in time, it provides a basis for understanding the physical source of high-potential-for-violence interactions between various members of the community.

“I learned to look at things from a different perspective and to look at the bigger picture.”

—Participant in Aug. 2010 project meeting

### High-Risk Interactions

Within the structure of the YVSP Strategy Lab, the slippery slope map serves another essential function: it creates the context in which high-risk interactions occur. A network of potential connections between individuals and groups exists within any community. Over time, interactions occur along the lines of connection. The further down the slippery slope, the riskier these interactions are in their potential for underwriting violent activity. What’s perhaps more important is the nonlinearity involved: as the distribution of youth in a community moves down along the slippery slope, the network of high-potential-for violence connections that underwrite high-risk interactions becomes disproportionately larger.

The figure below illustrates this phenomenon. In the left panel, there is a single less-organized gang. The right panel adds a second less-organized gang to the mix. Note the dramatic difference in the density of connections within the network—particularly the red connections that suggest a higher likelihood for violence.

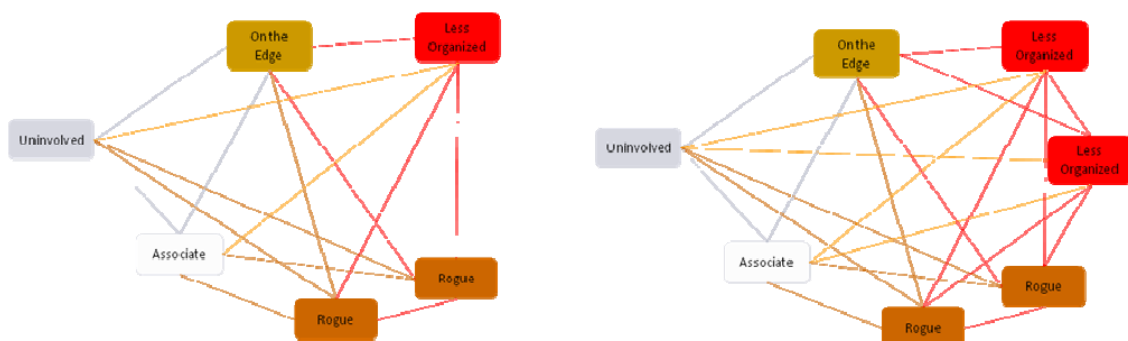

Figure 5. Illustrative High-risk Interaction Networks

In the YVSP Strategy Lab, we capture this network structure relatively simply. We begin by dividing each bucket of youth along the slippery slope into sub-groups called nodes. Connections exist between each node in the resultant network. The further down the slippery slope, the greater the flux over time of high-risk interactions along a connection. As an example, a connection between a rogue and a less-organized gang crew results in a higher number of high-risk interactions each year than a connection between two groups of uninvolved individuals.

### Community Trauma

Relatively early on in the project, we learned that many high-violence communities tend to exhibit behaviors that look a lot like the symptoms of post-traumatic stress disorder (PTSD). In particular, these communities tend to exhibit high levels of arousal (for example, hyper-vigilance). One implication of violence-induced community trauma is that sub-groups that comprise the community can misread social cues, transforming a benign interaction into one with potential for violence.

A simple feedback loop, shown at right, captures the reinforcing dynamic associated with community trauma. As the loop shows, other things equal, higher levels of community trauma lead to higher fluxes of high-risk interactions within the community, which in turn result in increased levels of community violence. To complete the thought, increased violence tends to drive community trauma even higher.



Figure 6. Feedback Around Community Trauma

### Affinity for Violence

It's been said that "if your only tool is a hammer, everything begins to look like a nail." This insight applies to many areas of life, and has particular applicability to this project. A simple feedback loop captures the dynamic.

The concept depicted here is straightforward: violence begets violence. More precisely, the loop says that the more one engages in violence, the more violence becomes the "default" operating mode for interacting with others. This, in turn, further fuels the cycle for those who take part in violent activity.



Figure 7. Affinity for Violence

### Tying it all together: Youth-Generated Violence

Slippery slope dynamics, high-potential-for-violence interactions, community trauma, and affinity for violence all come together in the generation of youth violence. The model

captures both gun-related violence and other violent activity among youth (think assault and battery). Because the YVSP Strategy Lab approaches drivers of youth violence from a highly physical, value-neutral perspective, it can facilitate individual and group investigation of initiatives aimed at changing the rates of movement of individuals along the slippery slope, as well as initiatives aimed at changing the nature of social interaction within the community.

## Interacting with the YVSP Strategy Lab

The YVSP Strategy Lab does not tell you how to best implement a policy, program, or initiative in the real system. It does, however, provide us with an experimental laboratory

**“This was good. We can talk about things better through this.”**

—Participant in Aug. 2010 project meeting

in which we can explore the implications of initiatives aimed at different parts of the system. By exploring this “policy space,” it’s possible to begin to identify potential high-leverage intervention points in the system. There are two primary points of interaction with the simulator: The “Configure Experiments” screen and the “Run Experiments” screen.

### Configure Experiments

The “Configure Experiments” screen, shown in Figure 8, is the first primary point of interaction with the simulator. It’s a bit of a mixed metaphor, combining the slippery slope map with a set of switches taken from the set of the movie *Young Frankenstein*. Users can activate initiatives in isolation or in combination by pulling the switches.

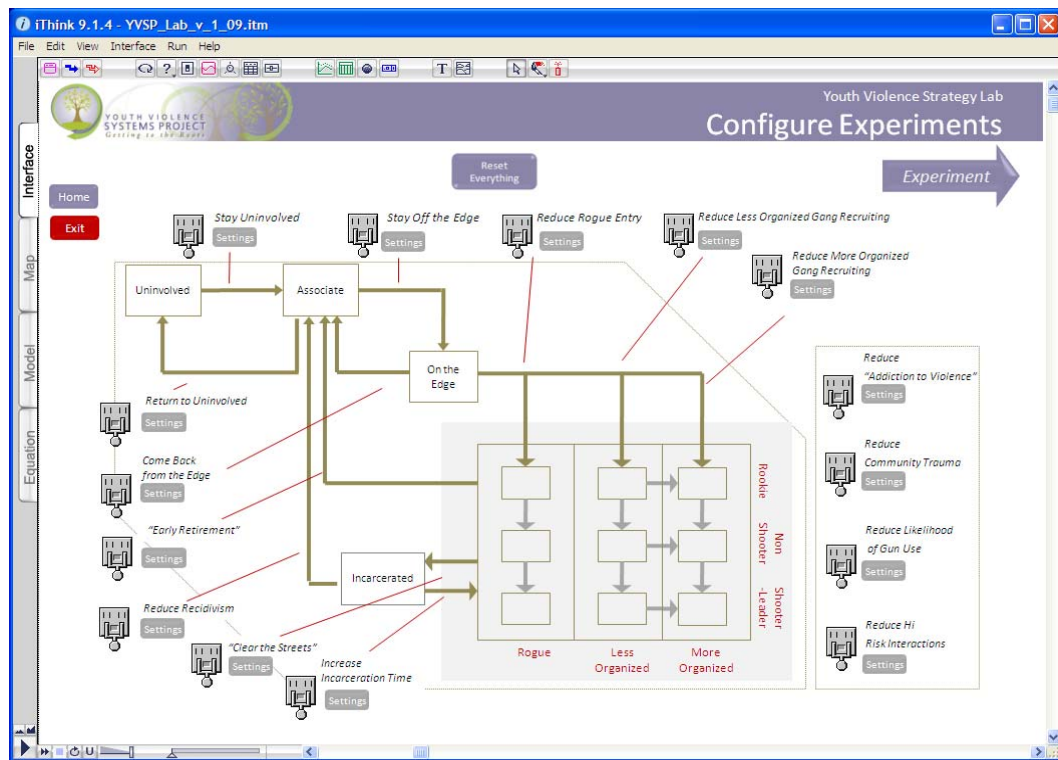

**Figure 8. YVSP Strategy Lab Configure Experiments Screen**

A click on the “Settings” button associated with each switch brings forth a new screen containing explanatory text and additional configuration options. Shown below, for example, is the settings screen associated with the “Stay Off the Edge” initiative.

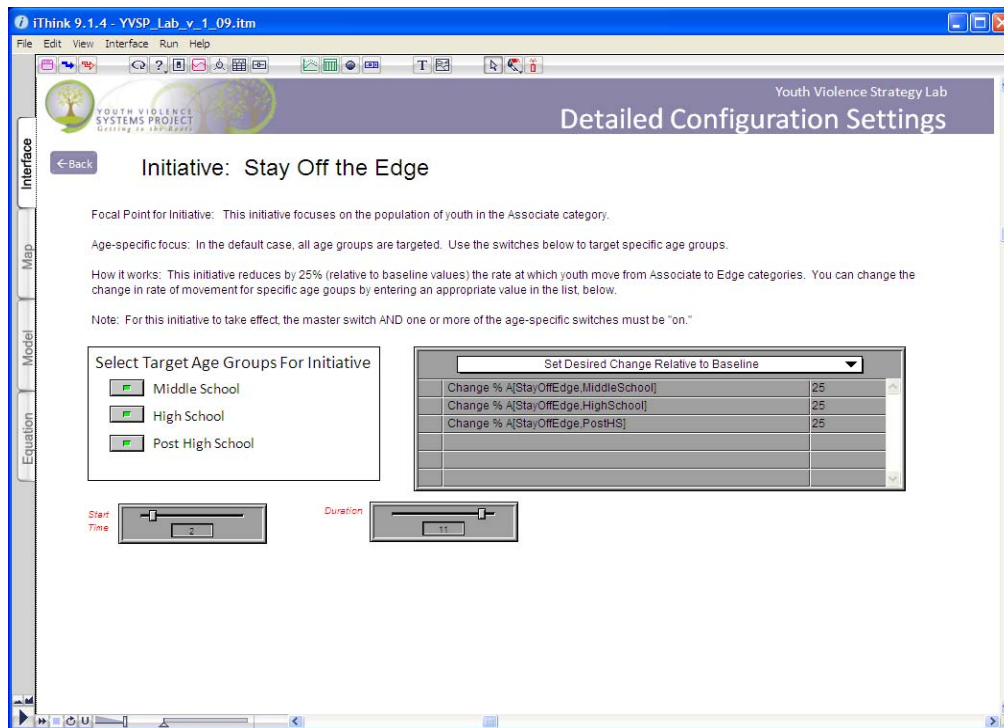

**Figure 9. Detailed Experiment Settings**

We encourage people to work in small groups to configure experiments. The discussions that result tend to be both focused and productive. We encourage people to think through the effect over time of a set of initiatives by sketching out the response of key community indicators (such as gun violence, gang involvement, etc.). We also encourage people to discuss in detail how a particular initiative might be implemented in their community.

### *Run Experiments*

Once an experimental setup has been configured, it's time to run a simulation experiment. Results are shown in graphs of behavior over time, as flashing warning lights, and as numbers. The model is set up such that if none of the levers are pulled, it generates relatively stable behavior over the twelve-year simulation horizon. On the other hand, when an initiative set “hits” the system, the graphs will show a response. Model output thus provides another touchpoint for focused group discussion.

*“I am now able to see, understand and explain where my organization fits in with other initiatives and organizations to reduce youth violence.”*

*– Participant in Aug. 2010 project meeting*

For example, on the next page is shown the result of an initiative that aims to stem the movement toward gang involvement, by focusing on preventing youth from moving from the “Associated” to “Edge” categories, and by accelerating the movement back from the

edge to “Associated”. The results suggest that this targeted initiative has potential for underwriting a significant reduction in violence among youth. Summer job or internship programs, by providing a meaningful alternative to “hanging around on the street” might be one mechanism for preventing the slide to the edge, or for returning from the edge of gang involvement.

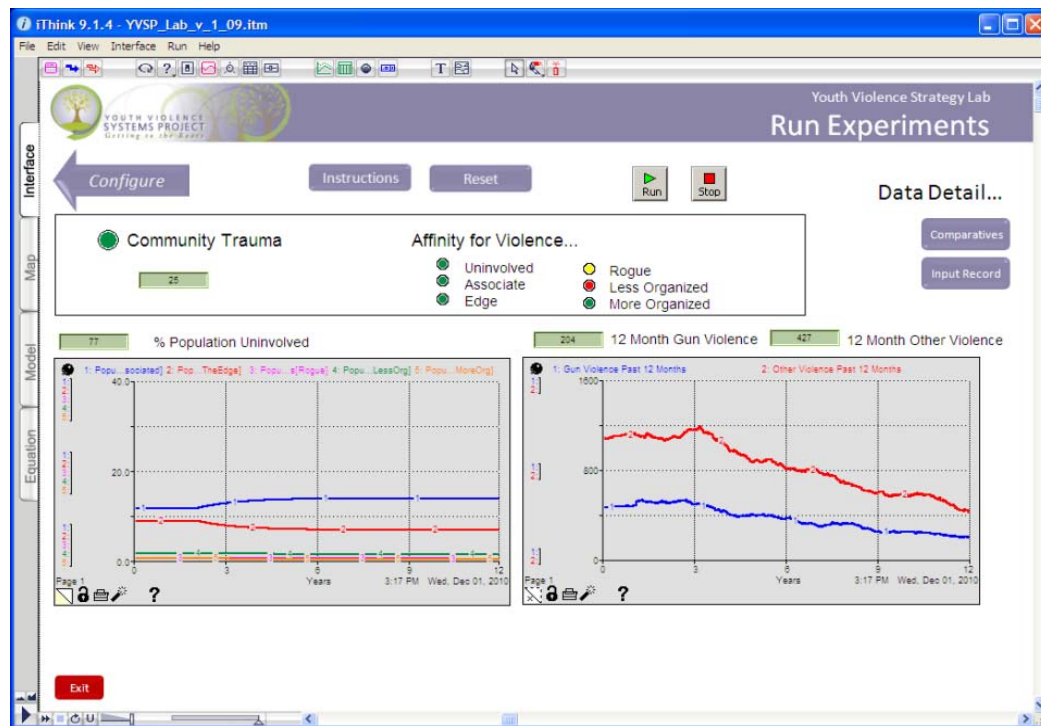

Figure 10. Sample Output

## Communities, Uses, and Potential Outcomes

Over the past several months, a wide range of stakeholders have interacted with the model, both in formal and informal settings. It is important to note that we have constructed the model for the communities that we are serving—it’s a tool that we think can improve understanding of youth violence in Boston and has potential to help communities in Boston to strategize and achieve sustained reductions in violence. That being said, it’s clear to us that there is potential value-added that can accrue to a wide range of stakeholder groups. The table on the next page provides our perspective on communities of interest, uses, and potential outcomes.

	Community	Agency	Policymaker	Academic Community	Funders	Gang Members
<b>Uses</b>	<ul style="list-style-type: none"> <li>Evaluate interventions proposed by others</li> <li>Evaluate interventions proposed by the community</li> </ul>	<ul style="list-style-type: none"> <li>Evaluate agency interventions</li> <li>Evaluate policies</li> <li>Communicate program effectiveness</li> </ul>	<ul style="list-style-type: none"> <li>Evaluate historic policy impact</li> <li>Anticipate future policy impact</li> <li>Design systemic policies</li> </ul>	<ul style="list-style-type: none"> <li>Evaluate historic intervention outcomes and impact</li> <li>Analyze impact of potential interventions</li> <li>Design systemic policies</li> </ul>	<ul style="list-style-type: none"> <li>Evaluate impact of past interventions</li> <li>Evaluate interventions proposed by agencies or policymakers</li> </ul>	<ul style="list-style-type: none"> <li>Evaluate how changes in their behavior impact the system</li> </ul>
<b>Potential Outcomes</b>	<ul style="list-style-type: none"> <li>Better informed community</li> <li>Improved community interventions</li> <li>Common language for discussing interventions</li> </ul>	<ul style="list-style-type: none"> <li>Better agency interventions</li> <li>Improved agency communication</li> </ul>	<ul style="list-style-type: none"> <li>Improved policy choices</li> <li>Improved system-wide intervention strategies</li> </ul>	<ul style="list-style-type: none"> <li>Improved analysis</li> <li>Improved system-wide intervention strategies</li> </ul>	<ul style="list-style-type: none"> <li>Better informed about where to invest funding effectively</li> <li>Improved community interventions</li> </ul>	<ul style="list-style-type: none"> <li>Improved engagement of gang members in intervention development</li> </ul>

## A Few Process Take-aways

As we began working on the YVSP Strategy Lab, we had great confidence, based on work in government and industry, that the effort to develop and roll out a dynamic model could help us to meet the Project’s twin objectives of improving the understanding of community-based violence in Boston, and of helping communities to strategize and achieve sustained reductions in violence. And yet...we approached the effort with more than a tiny bit of trepidation. Would systems thinking be too ivory-tower-academic for the communities involved? Would people engage with the simulator? Would the technical aspects of the simulator overwhelm users? Happily, these fears have largely been unfounded. In fact, we’ve discovered some important aspects about the intersection of system dynamics and community engagement around a critical social concern:

- Community members take to the systems approach that underlies the simulator. Systems thinking “feels real” to them.
- Youth in particular “get” the logic of systems. They understand systems insights, and are able to analyze the model without difficulty.
- Within the community, there seems to be strong intuition for interdependencies—but perhaps not a language for making sense of how interdependencies come together to produce undesirable results such as youth violence. Community members seem to understand that “everything is connected to everything else,” but they don’t necessarily have the tools to take action on that understanding.

- This stuff (stocks and flows, nonlinearities, feedback, and the strategy laboratory concept) provides a working language for sense-making, advocacy, and empowerment .

## What's Next

Dynamic simulation models such as the YVSP Strategy Lab tend to evolve in fits and starts over time to meet the evolving needs of stakeholder groups. The version of the model illustrated here has been stable for several months, but important changes are in process. While the first version of the model focused on the *city* of Boston, a second version will focus on a more narrowly-defined set of *communities* within Boston. This more narrow focus will enable us to better understand the dynamics of specific neighborhoods, and may help to support the development of community-specific interventions.

In addition, there is potential in the coming months to broaden the base of users of the model. For example, projects outside of Boston have expressed keen interest in learning more about the model and about the process used here. In a similar fashion, faculty from a range of different disciplines have expressed an interest in using the model as part of their curriculum. Because we have designed the model to provide a framework for improving the understanding of community-based violence, we believe that the simulator may be able to support the efforts of these emerging communities of users.

The YVSP Strategy Lab is a powerful tool, but it's important to remember that it is only a tool. Used skillfully as a device for inquiry within the context of a community-centric process, the tool has potential to engage and empower community members as they strategize initiatives to achieve sustained reduction in violence. On the other hand, the tool has potential to cause damage when used as a polemic device to "prove" pre-conceived notions! Accordingly, we are making haste (but slowly) as we consider next steps for the model. We will take measured steps as we broaden the base of users. And we'll continue to rely on the community-based process that has brought the model to where it is now.



## THE REASON WHY WE HAVEN'T SOLVED THE GANG VIOLENCE PROBLEM

Khary Bridgewater

The Youth Violence Systems Project (YVSP) was initiated to empower the community's perspective on youth violence in Boston by creating a framework for developing intervention strategies that lead to real change. Since 2008, YVSP has been using a community-based approach coupled with systems dynamics modeling to create a virtual laboratory to model youth violence intervention strategies. Our goal is to help develop the capacity for deep and honest dialogue among a wide range of people to collaborate toward a shared goal of reducing youth violence in our neighborhoods.

This article discusses how the YVSP team solicited the input of gang members in the design process, and describes the findings and insights gained. In addition, the story of the YVSP process is further told in three related articles:

- **The Youth Violence Systems Project: A Community-Based Framework of Understanding Youth Violence in Boston** gives an overview of the community-based process that is at the heart of YVSP. It also gives a brief introduction to the content covered in more depth in the other three articles.
- **The YVSP Strategy Lab** describes YVSP's system dynamics model in detail, including an introduction to the key systems concepts for understanding the model.
- **What We Are Learning** describes how the model is being used in various settings, and what different folks are learning from the discourse so far.

### What I know about gang violence is wrong

Having worked with high-risk and gang-involved youth for nearly 20 years, I thought I knew a thing or two about gang violence. I have preached, lectured, and written about the reasons Black males are victims and perpetrators of violence, often citing my own personal experiences growing up in one of the most violent cities in America.<sup>1</sup> I have read hundreds of articles, research findings, and opinions about violence from the criminal justice, sociology, and public health fields. More importantly, I have had close personal relationships with gang members and a number of friends and family who have been victims of gang-related violence. Despite all of this, I have come to the sober conclusion that what I know about gang violence<sup>2</sup> is wrong.

I, like most “gang experts,” am familiar with the myriad rationales for the existence of gang violence. These range from structural reasons like concentrated poverty and inequality, to cultural reasons like “street codes” and a culture of violence, to social reasons like fatherlessness, family decline, and community tolerance. The clustering of violence in certain neighborhoods where these structural, social, and cultural phenomena occur seems to confirm that somewhere within the mix of these perspectives lies the cause of gang-related violence. For years now, researchers have told us that young people join gangs for

protection, respect, fun, money, and acceptance. And all gang workers know that the way to deal with gangs is a mix of prevention, intervention, and suppression. Yet if we know so much, why isn't there a single example where a U.S. city has definitively ended gang violence, or kept gangs from forming and proliferating?

We continue to fail in solving this problem not because of a lack of commitment, investment, or intelligence. We fail because we have used the wrong tools to try to solve the problem. And as long as we approach this problem incorrectly, we will continue to be wrong about what we know about gang violence. For example, I thought that the higher number of murders occurring in September was a statistical anomaly and that the most dangerous time for gang violence was in the summer. I was wrong. Gang members have told us that they actually prefer to kill in colder months. I thought that most gang violence was sanctioned, vendetta-based killing. I was wrong. Most gang violence is interpersonal violence that is reinforced and escalated by preexisting gang conflicts. I thought that gang members had few personal ties to members of opposing gangs, which enabled their ability to act in callous and violent ways. I was wrong. Most gang members in Boston have close, complicated, interpersonal relationships with opposing gangs—often being childhood friends and relatives of those they are actively trying to kill. Finally, I thought that changing youth attitudes about violence was responsible for the recent increases in violent behavior. I was mostly wrong. While attitudes toward murder have changed, the dominant force driving levels of violence upward is the fact that there are simply more gang members with more opportunities to get involved in violent conflict.

How do I know now that I was wrong? I know because we have found a better way to learn and think about this problem. The tools that helped me challenge and refine my assumptions about gang violence are tools that are available to all of us and must be brought to bear to improve collective understanding about this seemingly intractable problem.

### **I thought you would have the answers!**

A few years ago I was invited to attend a roundtable discussion at the William Monroe Trotter Institute at the University of Massachusetts Boston on violent crime in Black neighborhoods. More than 50 of Boston's most influential individuals participated, including religious leaders, elected officials, educators, academics, law enforcement officials, social service providers, youth workers, youth, and community activists. For a few hours we discussed the reasons for the high rate of crime in Boston's Black neighborhoods, the resources and strategies required to reduce violence, and whether partnerships could be formed to address these issues.

Despite the wealth of knowledge and insight in the room, the conversation devolved into the same predictable patterns: prevention specialists decried the lack of sufficient attention and funding to keep young people from joining gangs; gang workers called for more resources to help current gang members leave the gang lifestyle; and law enforcement professionals advocated that suppression was the only proven strategy to quickly and consistently reduce violence. Just when I was prepared to chalk this up to another typical gang violence discussion, the unexpected happened. An unassuming woman spoke up. She announced that she was a community resident and then, nearly sobbing, she blurted out, "I

came to this meeting because of all of the violence happening in my community. I thought you would have the answers! But as I listen to you all, you don't have any answers! If you all don't have the answers, who does?"

This uncomfortable outburst cut through our façade of knowledge and expertise, exposing an ugly truth. We were speaking as if we had answers, but in truth we had only cobbled together a morass of assumptions and shared narratives. As the discussion resumed, I wondered silently to myself, "If we already know what is going on with gang violence, why hasn't *anyone* solved this problem?" In that moment I came to the conclusion that what I know is wrong and that none of us had the answer to gang violence. It would take me some years to figure out why.

### **Wicked problems, reductionism, and the search for truth**

Part of the problem that we faced at the roundtable was that we were approaching the problem from different perspectives, disciplines, and assumptions. What did we mean when we used the word "gang"? We all had a strong sense of what the word meant, but just as strong were the differences in meaning. In fact, researchers tell us that there is no uniformly accepted definition of a gang. Add to this ambiguity the lack of shared definition around gang violence (are we talking about interpersonal violence committed by gang members, or general vendetta-based gang violence, or targeted gang-authorized violence?), and we begin to see how hard it is to even define the problem.

A further challenge is revealed by the number of disciplines that have attempted to evaluate and address gang violence from their professional perspective. Gang violence is a highly complex social phenomenon that impinges upon a wide range of social sectors, including health, education, crime, employment, and the list goes on. According to social planning theorists, gang violence would be considered a "wicked problem." It fits that class of problems that are difficult to solve because of incomplete, contradictory, and changing requirements, and furthermore, the complex interdependencies mean that solving one part of the problem may create other problems.<sup>3</sup>

The failure to understand what it means for gang violence to be a wicked problem explains why so many of the solution approaches<sup>4</sup> have led to less-than-satisfactory solutions. Anyone who would be considered an expert in the field understands that gang violence is not a simple problem where you apply knowledge in your field or another field to fix a problem. However, most tend to see it as a complex problem where the system responds the same way to repeated stimuli (i.e. we know what worked in the past, so we should just do it again). The solution approach for complex problems involves uncovering the recurring patterns and designing a solution around those patterns. This approach also lends itself to reductionism where you break the problem down into component parts and solve each piece. These local solutions can then be aggregated to solve the entire problem.<sup>5</sup>

Name	Category	Characteristics	Action
<b>Simple Problems</b>	<b>I</b>	Solution knowledge exists in your own domain.	Redirect attention.
	<b>II</b>	Solution knowledge exists in another domain.	Find an expert. Become an expert and design own solution.
<b>Complex Problems</b>	<b>III</b>	No solution exists in any domain; system is very complex but responds the same way to repeated stimuli.	Explore for recurrent patterns by probes and experiments. Design resolution around recurrences discovered.
<b>Wicked (Messy) Problems</b>	<b>IV</b>	No solution exists in any domain; system is chaotic and adaptive, does not repeat patterns under the same probes.	Organize collaboration in a local part of system, and then spread the new organization to the whole.

Gang violence on the other hand is not just a complex problem but a messy or wicked one. The system in this case is chaotic and adaptive, so just when you find something that works the system changes unexpectedly, and repeating past success becomes impossible. Additionally, gang violence is non-linear in that behavior taken in one part of the system triggers feedback in another. For example, increasing the rate of incarceration of older gang members is countered by increased recruitment and faster apprenticeship of younger gang members, which creates a new set of unexpected problems over time. Therefore attempts to replicate past success and best practices from other places will most likely meet with worse than expected results.

This resistance to reduction and linear analysis presents direct challenges to traditional research approaches. The accumulation of information around sample sets of gang members and gang violence may at best give snapshots of a particular system at the point in time of analysis. But this work tends to fail at predicting the dynamic behavior of gang violence over time not just because of the complexity of the system but also because of the inherent chaotic non-linearity. In other words, the target is always shifting, just when you seem to have a sense of how it behaves. Furthermore, the division of disciplines leaves us with disparate approaches evaluating different parts of the system such that even our snapshot of the system is at best a jigsaw puzzle, and at worst can lead us down the path of the blind men and the elephant with no one stepping back to see the whole system.

### Getting to the roots—what’s happening beneath the surface

One of the challenges to conventional wisdom about gang violence is that it is more than just a series of violent events. It is a complex tangle of interconnected phenomena that changes its behavior—often unpredictably. One important reason that what I know about gang violence is wrong is that gang violence has fundamentally changed. Growing up in Michigan, much of gang violence was territorial and connected to drug trafficking. Police tell us that this is no longer the case.<sup>6</sup> Back then relatively few people had access to guns, and automatic weapons were hard to come by. Now they are cheap, available, and extraordinarily lethal. Finally, the sheer number of gang members and gangs has changed. In Boston alone, there has been an order of magnitude increase in the number of police-identified gangs skyrocketing from approximately 15 in the '80s to over 115 in 2010. In some places gangs have become entrenched community institutions.

Another challenge to conventional wisdom about gang violence is that popular attitudes toward gangs have changed. The increased number of gang members has also meant that there has been an explosion of non-gang members that have close relationships with gang members. Gangs moved from small groups of kids to community entities where nearly all of the young people in certain neighborhoods identify themselves as having a conspicuous relationship with a gang member. This shift then challenges the conventional wisdom that the problem of violence is limited to a small number of gang-involved youth. Not only has this group grown in size but in certain high-violence neighborhoods gang culture and gang acceptance has spread rapidly. The proliferation of “no snitching” merchandising a few years ago was an early indicator of increasing tolerance for vendetta-based violence. This growing culture of lawlessness is influenced by the increasing association of community residents with peers and family members who have been incarcerated. The preeminence of gangster rap and its cultural impact has also created an alternate career path in the minds of many youth of the gangster/drug dealer turned rapper. Most disturbing is the transition from wanting to join a gang and become a member to wanting to become a shooter and build a reputation as a killer.

As these changes to the nature of gang violence were happening beneath the surface, gang research was expanding. While excellent research has documented many trends over the years, this work has existed in institutional and professional silos. Moreover, key insights were missed because of the limitations of the tools often used to evaluate gang behavior. Much of the published research with gang members employs surveys and interviews of individuals, which are techniques that don't typically allow for the development of deep trust with the subject. The limitations of these techniques create a basic barrier to understanding the inner workings of gangs, which behave as a closed subculture. Additionally, initial conversations with gang members produce well-worn and generally accepted narratives regarding why they joined a gang, how they feel about being in a gang, why they engage in violence, and what would cause them leave. Over time, however, gang members can be encouraged to spend time in introspection to provide more authentic and accurate answers.

The tools employed by the different disciplines that study gang violence also lack a single overarching framework and language. A simple question “How do we reduce gang violence?” may be interpreted differently by police, gang workers, youth workers, and community activists. These differing interpretations may lead to distinctly different and sometimes contradictory solutions.

## The Wisdom of Systems

In addition to the challenge of establishing a shared language about gang violence, there is also an overwhelming sense of interconnection that may lead to frustration and paralysis. One community resident described it as “everything is connected to everything.” The sense of threat, lack of progress, social paralysis, active resistance, and negative moods associated with gang violence is described by Denning<sup>7</sup> as the signs of a social mess or wicked problem. As I stated earlier, this type of problem requires a different type of approach.

Wicked problems, in addition to being chaotic and adaptive, cannot be solved by the normal approach of defining the problem, analyzing the system, and solving the problem in sequential steps. Roberts describes three approaches to solving wicked problems: authoritative, competitive, and collaborative.<sup>8</sup>

The **authoritative approach** vests power to solve the problem in the hands of a few. This approach is best reflected in the way that the public sector tends to address the problem by convening action groups and committees. This approach, however, often misses important parts of the system that are unfamiliar to the authorized group.

The **competitive approach** considers opposing views which vie to demonstrate better results and gain acceptance as the superior solution. The competitive nature of interdisciplinary discourse among academics exemplifies this approach. An adversarial approach can create an environment where the winner takes all that can disincentivize communication and idea sharing.

The **collaborative approach** seeks to incorporate many stakeholders who are engaged in finding a solution often by meeting to discuss issues and develop an accepted approach. This approach requires time, effort, and skill in facilitating collaborative work. Typically those affected by the problem are part of the design process.

I believe that the failure to use a structured collaborative approach effectively explains some of the limitations to addressing the messy, wicked gang violence problem. The process described below demonstrates the methods and benefit of using what Senge<sup>9</sup> calls a “pilot group model of change” to “organize collaboration in a local part of system, then spread the new organization to the whole.”<sup>10</sup>

## A Different Approach

In 2008 the Youth Violence Systems Project (YVSP) was launched to explore the root causes of youth violence in Boston. Early on we adopted the view that youth violence was a big, messy, systems problem where there was no consensus for defining the problem or for developing a solution. We also concluded that the perspective of those most affected by youth violence was essential to developing a framework that would be useful. Our hope was that a better understanding of the mechanisms and dynamic behavior that drive youth violence would help the community change the output behavior of the system, leading to a sustained reduction in youth violence.

At the outset we knew two basic facts. First, our literature review and secondary research showed that gang violence in Boston occurred in hotspot areas. It had been known for some time that gang violence occurred in certain high-violence neighborhoods and along a few key corridors like Blue Hill Avenue. Second, our conversations with Boston police officers and the research conducted by local analysts showed that most acts of violence were conducted by a small number of gang members.

### *Ask a different question*

At the suggestion of Steve Peterson, our model builder and systems expert, we began our

work by asking a different question than usual. Most research around youth violence tends to ask one of two different questions: either what was happening with gang violence or why it was occurring. In our case, great research had already been conducted in Boston addressing *what* was happening. Steve wisely counseled us *not to ask why* because that typically only elicited the assumptions, false familiarity, and anecdotal narratives of those being asked. So we asked *how*. “*How precisely is gang violence occurring in high-violence neighborhoods?*” Understanding how gang violence was occurring in the real world would tell us much more about the problem than gathering a list of people’s thoughts. “Besides,” Steve said, “if you understand how, then it will help you to understand why.”

I was particularly concerned about the false familiarity of people like me, who had grown up with the gang problem but hadn’t realized how much had changed in the past 20 years. I also was wary of the plethora of popular narratives floating around that were either inaccurate or outdated. One “research finding” I heard over and over from gang workers was that the majority of gang violence was attributed to a few very violent extended families in Boston. After asking researchers for hard data to support this popular claim, it was discovered that this supposed finding originated as a hypothesis in a PowerPoint presentation made to gang workers.

### *Ask different people*

It was always important to ground the Project in the reality of people experiencing and perpetrating gang violence. We therefore decided to spend the majority of our time asking questions and learning from residents of high-violence neighborhoods. In addition to the practical benefits of going closer to the source, we knew that community residents have local knowledge and expertise about neighborhood dynamics and the success of violence prevention initiatives. So we held in-depth interviews and private briefings with community residents, community-based agencies, and academic and institutional stakeholders.

We discovered that there was a large disconnect between what was actually happening in high-violence neighborhoods and what was understood by researchers. It became clear that a tremendous cultural divide exists between community residents, academicians, policymakers, and social service professionals. This cultural divide was further complicated by race and class issues. Residents also described a history of patronizing behavior and the failure to listen by researchers and policymakers, leading them to believe that “outsiders” did not understand the basic realities faced by people living in their neighborhood.

### *Ask a different way*

We understood that the residents of high-violence neighborhoods in Boston had participated in numerous research initiatives, and many described feeling research fatigue from being overanalyzed. We therefore developed an exploratory inquiry process in which community residents participated with researchers in designing a solution approach to engage the problem of youth violence using a systems perspective. The key idea was that the team would explore how to think about the problem together.

This exploratory inquiry process involved four key steps:

- **First**, community residents were educated about the topic and the methods we would use to approach the problem. This initial training was done to ensure that there was shared understanding around what we meant when we asked and answered questions together.
- **Second**, we committed ourselves to work over a longer time frame than usual. This commitment was made to ensure that a sufficient amount of time was allowed to build trusting relationships among the partners.
- **Third**, we intentionally challenged the false familiarity and accepted anecdotal narratives held by practitioners and community residents. These challenges were made to ensure that our work proceeded from the basis of observable phenomena in the real world instead of theoretical suppositions.
- **Fourth**, we committed to comparing the implications of all expert conclusions with community realities and vice versa. This commitment was made to further ground our work together in objective reality.

### The Youth Violence Systems Project as a Case Study

At the heart of the YVSP approach was the use of a community learning process which was employed to build a system dynamics model of youth violence. The Project approach consisted of 10 key steps:

1. Conducting a multidisciplinary literature review.
2. Convening large-scale discussions with local and national experts, practitioners, and stakeholders.
3. Identifying and challenging the dominant assumptions about the violence.
4. Establishing an integrated framework based on socio-ecological theory.
5. Conducting a force analysis to determine how key social forces came to bear on the system of youth violence in Boston.
6. Defining the boundary of inquiry for the problem.
7. Engaging the community in an exploratory inquiry process.
8. Capturing these findings in a system dynamics model.
9. Refining model assumptions with feedback from multiple stakeholders.
10. Helping community residents use the model to address the problem of gang violence.

While community residents served an essential role in the Project design and execution, they expressed concern that they knew very little about the behavior and motivations of gang members. It was therefore decided that active and former gang members needed to participate in addressing the problem of violence.

#### *Approach*

We held two focus groups with gang violence experts to help us determine a way to safely and effectively engage gang members in the Project. We enjoyed the benefit of having a

number of consultants with experience with previous gang violence initiatives in Boston. One encouraged us to go deeper with gang members and ask them to provide detailed information about their personal experiences instead of providing us with general information about gang violence. Another advised us to avoid standard one-on-one interviews, adopt a more anthropological approach, and spend large amounts of time interacting with gang members as a group. His perspective was that this approach would help build trust with gang members as well as provide more opportunity to observe and understand the meaning behind their responses.

We therefore developed a very direct, interpersonal approach to our inquiry process. Over the course of the Project, our gang violence experts helped us develop stock/flow diagrams to describe the movement of young people in their involvement in gang violence. These diagrams served as a mechanism for sharing insight and understanding among Project participants. They also provided a value-neutral focal point for discussion, helping people from different backgrounds come to a common understanding of the interrelationships that impact violence within the community.

We decided to ask gang members to correct and refine our assumptions that undergirded these diagrams. Our rationale was that gang members, while part of a semi-isolated subculture, are still people who care about reducing violence in their neighborhoods. Our approach was to respectfully invite them to participate in a community-wide response to reducing violence as expert consultants who were sharing their personal experiences for the positive benefit of the community.

### *Methodology*

We began with the assumption that there are at least two types of gang members: those who were younger and actively involved in producing violence, and those who were older and responsible for leadership and managing the organization of the gang. It was then decided to engage these two groups separately using different methodologies.

We decided to partner with agencies that were deeply engaged and experienced with gang members and noted for having long-term, trusting relationships with key violent individuals. The partner agencies were hired to work in conjunction with the Project staff to design and co-facilitate the focus group sessions, create appropriate questions, and recruit key gang members to participate in the Project. The partner agencies leveraged their existing relationships with violence-producing individuals to form two focus groups: the first group consisted of active gang members aged 18-23; and the second group consisted of older men aged 22-40 who either had a history of gang involvement or violent offending (in some cases founders of gangs were included). The participants in the focus groups were hired as consultants and tasked with providing information about the methods and rationale for gang violence as marked by their own personal experiences as victims and perpetrators of violence.

The first group consisted of “shooters/enforcers” from two allied gangs. They met four times for two-hour focus sessions once a week for a month. Each participant was identified using an alias and paid by the partner agency in cash for their time. During the course

of each two-hour session, participants were asked a series of open-ended questions designed to elicit increasingly in-depth responses about their experiences, perceptions, opinions, feelings, and knowledge of methods and motives for gang violence.

In keeping with the Project's dynamic framework, a narrowly defined line of questioning was used which focused on the physical methods and direct causes of violent behavior. A scaffolding approach was used to move the discussion from less personal questions to more personal questions as trust was built over the course of the sessions. I began by describing my own personal experiences with gang violence to bridge the gap between us and to establish a reference point for violent behavior. We then had a baseline to assess the difference between gang member responses and what a "normal" response would be to a particular question.

Below are a few examples of how the process worked. To establish initial rapport, I described in detail my personal experience being recruited by two national gangs as a youth growing up in Michigan. I then asked them to describe their experiences with being recruited into a gang. To assess the limits of the brutality typically displayed in their violent behavior, I described in detail an extremely gruesome murder of a friend<sup>11</sup> and asked them if they knew of any murders like that. They described how there were limits to how violent their actions were in part due to the limited time they had to commit a murder and leave the scene before police arrival (which they regularly timed). To provoke introspection regarding leaving the gang lifestyle, I discussed my desire to keep my newborn son away from the violence that I grew up with. I asked them if they had children and if they ever thought of things like this. They went on to describe their hopes and dreams about getting out of violence and keeping their children away from their violent lifestyle.

In some instances these questions were informed by responses to previous session discussions. This method was used initially to reinforce the fact that we were listening carefully to their responses and processing them in between sessions. It also was designed to prompt a running dialogue where they would engage in personal reflection between sessions. It was particularly helpful as we noticed that some answers changed between sessions as they took the time to think more deeply about the question. For example, they initially described the reason they wanted to "fall back" from being key shooters in their gangs was because they were tired and thought it wasn't fair that the younger gang members hadn't "put in enough work." But over time they began to describe other reasons for wanting to reduce their violent role, stating that as they got older and made more money "they had more to live for." Interestingly, this reasoning indicated an inverse between life satisfaction and the willingness to take primary responsibility for committing violence on behalf of a gang.

Answers also changed as follow-up questions were presented to test the veracity of the initial answer. During the first meeting the allied gang members spoke highly of their commitment to each other's gang and their personal closeness. During the second session, however, a younger gang member joined the session, and it was revealed that the younger members of the two gangs had recently shot at each other. An older gang member from the first gang challenged a younger gang member of the second gang, asking him why he shot at members of the first gang. His answer was that they shot first, and this was consid-

ered an acceptable reason to shoot back. (We were informed later by the gang workers that we had been allowed to witness an important reconciliation conversation between the two gangs.) After the situation appeared to be resolved, I asked the gang members what would have happened if someone had been killed in the shooting exchanged by the younger gang members. They somewhat sadly replied that if someone had died then they would no longer be friends. It would be war. And so, despite their repeated expressions of friendship earlier, it was clear that this alliance had limits and an inherent instability in which the person who was your friend could quickly become your enemy because of the dynamic nature of gang violence.

The second group of “founders/leaders” met one time for a four-hour focus session. Each participant was paid by the partner agency in cash for their time. During the course of the session, participants were asked a predefined set of questions that had been developed jointly by the partner agency and YVSP staff. A question was read by the gang worker to the group, and each gang member provided an initial response. I then initiated follow-up questions and/or discussion to elicit deeper, more personal responses.

Concepts raised with the first group of younger “shooter/enforcers” were revisited with the “founders/leaders” group to test for reproducible answers and to gain more insight into the context of the earlier group’s responses. For example, the first group said that it was essentially impossible to get out of the gang once in. The “founder/leaders” stated, however, that this impossibility was true for active shooters, but there were a number of ways to move out of the forefront for older members or for those who had different roles in the gang. Shooters also described the permanence of gang affiliation during and after jail. The leaders stated, however, that affiliation could change if the gang member was in jail for an extended time or if they were sent into the prison system (most shooters spent time in the county jail system).

The “founders/leaders” also provided a longer-term perspective regarding the formation, adaptation, and ending of gangs. They described the process that gang members go through moving from rookie, to shooter, to leader. They also described an alternate pathway in which a gang member may become an earner by making money for the gang through drug trafficking and eventually become a leader. They discussed advancement in the gang in terms of respect and productivity. They discussed the adaptive nature of their recruiting strategies to ensure the growth and survival of the gang. They also outlined the intricate interactions between gangs and law enforcement over time. For example they described how gangs that begin to make money may find themselves having more trouble because of dealing with growing jealousy of rival gangs and increasing scrutiny from federal law enforcement.

Interestingly, none of the “founders/leaders” recommended the gang lifestyle for younger people. They specifically wanted to remove the glamour of gang life and show the reality that gang life is a “hustle” that you can’t do forever. One leader put it this way, “When I was young, I believed there was a pot of gold at the end of the rainbow, but I found out that it was a pot of sh\*t.” Despite their strong feelings, however, most felt limited in their ability to impact younger members because of their role as leader to preserve the gang and because of their aversion to appearing hypocritical.

Data gathering and evaluation consisted of verbatim quotations and observation notes, reflective listening, along with individual and group observations. In addition to co-facilitating the sessions, partner agency staff also assisted in evaluating and interpreting the data. Consultants experienced in working with proven-risk and gang-involved youth were hired to provide additional evaluation of session data. Care was given to corroborate focus group data with other data sources and the perspective of experienced youth workers.

### **What we know now, and why we know it**

I attribute much of our ability to generate a significant body of primary data about the rules, norms, behaviors, and motivations of gang members to the unique nature of our solution approach and interview methodology. There are five key findings that we have learned that are worth noting.

#### *Increasing violence is driven by dramatic increases in gang members*

We noted earlier that there has been an unprecedented increase in the number of gangs and gang members in Boston since the 1980s. What this increase means for gang violence is not as clear as it seems. While more gangs would suggest more violence, the relationship between the two appears to be far from linear, and the impact seems far broader than some may expect.

Our first indication that something significant was happening in high-violence neighborhoods around increased gang presence came from our discussion with non-gang involved youth. We initially assumed that most youth, even those in high-violence neighborhoods, did not have close or conspicuous relationships with the small number of violent, gang-involved youth. Discussion with non-gang youth revealed, however, that nearly all of them reported having close associations of some sort with gang members. One youth stated, “I don’t know anyone in my neighborhood who doesn’t have an association with a gang member. I think it’s impossible to not associate with them where I live.”

The seemingly ubiquitous presence of gang members in a few small, geographically contiguous areas in Boston suggests that there is a high likelihood that these individuals will have more interactions with other gang members. The higher number of interactions means that there is the likelihood of a corresponding increase in potentially violent incidents—especially since gang members report that most gang violence is interpersonal violence driven by personal disagreements that are sanctioned and reinforced by the gang.

Increasing numbers of gangs also means that there are increasing orders of complexity to gang conflicts and alliances. These circumstances create an environment for shifting gang behavior where violence moves from targeted killing (as is the current norm as described by gang members) to more opportunistic shooting.

#### *Traumatic stress is changing the way nonviolent youth behave*

As nonviolent youth experience more and denser social networks which include gang members, they experience increased levels of traumatic stress associated with the community violence that is happening in close proximity to where they live and go to school.

This stress is possibly increased because of their personal relationships with the victims and perpetrators of this violence. Others have already discussed how traumatic stress may lead to recurrent interpersonal violence for non-gang involved youth because it is both a result of and catalyst for violent behavior. This expanding impact of violence may not only help to explain the localized or “hotspot” nature of gang violence, but it also may explain why other forms of interpersonal violence trend in correlation to gang violence in a community. In the simplest sense, these non-gang involved youth have become the collateral damage of ongoing gang violence as their normal behavior and response to stimuli are changed by the stress they encounter living in high-violence communities.

### *Gang violence is addictive*

An unexpected finding was that gang members described violence as intensely addictive and reported using violence as a way to manage their emotions. They discussed how they used violence to: “release tension” associated with grief; abate generalized anger; and manage arousal through thrill-seeking behavior like “forcing” conflict with others for personal reasons. They described experiencing extreme fear and recurrent “flashbacks” from the first time they shot or killed. They also recounted a sense of time slowing down, physical shaking, and in some cases blacking out associated with their going into “killing mode.” They relate this hypersensitivity to the fact that their bodies are just reacting because “when you see someone pulling out a gun, you don’t have time to think you just react...” They all agreed that killing is like a drug, and they feel a “rush” associated with violence. This sense of rush and excitement seems to diminish as they continue to engage in repetitive violent behavior over time.

Taken together, these descriptions suggest a demonstration of salience, relief, tolerance, and conflict associated with violent behavior for certain gang members. These experiences correspond with Hodge’s suggestion that reinforcing cycles of traumatic stress and violence exist where individuals, traumatized by their own violent actions, may become addicted to violence as demonstrated by the use of violence as an active strategy to manipulate emotional well-being.<sup>12</sup> The presence of such an intensely violent subculture, where the use of violence as a dominant mechanism for managing well-being is normalized, may explain why some initiatives have results that differ from expectations when attempting to modify violent behavior.

### *There are significant unintended consequences of suppression strategies*

The practice of suppressing gang violence by arresting large numbers of violent offenders to stamp out violence is a proven way to reduce gang violence in the short term. Gang members acknowledge that these arrests are an effective way to shut down the spiral of retaliatory violence once a key gang murder occurs. There are, however, a number of unintended consequences associated with the suppression strategy that gang members relay.

This strategy typically involves arresting known shooters on non-violent charges to quickly get them off of the street, to cool down retaliation cycles. The average incarceration rate for these arrests is about two years, and often jail terms are served in the local county jail system. The long-term impact of this strategy is dramatic.

First, it means that many more gang members have criminal records and have spent time in jail than ever before. This reality has fundamentally changed the way they and those in close relationship to them view jail. Most shooters say that they are used to jail, but they report becoming “tired of jail” by the time they approach their third incarceration. Older gang members who have been threatened with or actually spent 10 or more years in prison describe how the threat of going to jail for such a long time has significantly changed their outlook. The widespread use of shorter jail terms for younger “shooters” has meant that the widespread familiarity with shorter jail terms has undermined its use as a deterrent to violent behavior.

Second, shorter gang sentences have meant that gang members are able to maintain their gang affiliations in jail. Their relationship to the gang may change during incarceration but they typically return to society with similar affiliations with their gang. Gang members who have been sentenced for longer terms or who have entered the larger state or federal prison system report that gang affiliations necessarily change during incarceration to fit into the powerful prison network of gangs. This change causes prisoners to choose affiliations based upon trust and respect and may mean that they may find themselves in gangs with former adversaries. This long-term affiliation and collaboration with former enemies seems to produce an ability to discuss conflict and talk through issues. A number of instances were relayed where founder/leaders described coming to a place of forgiveness and resolution with former adversaries. This sort of introspection and skill development was not reported by shooters who typically served less time.

Third, gang members described how the breakup of gangs targeted by the police had changed the way they as leaders managed how violent things become to avoid crackdowns. When crackdowns do occur, however, they related how this shift created the environment for “side street” gangs to emerge. After the initial dismantling of a major gang, youth in the neighborhoods of the gangs seek to join other existing gangs for security and belonging. Over time these youth often decide to form their own neighborhood gangs. This behavior suggests the suppression of a large gang may lead to the spawning of new smaller gangs over time. Gang members point to this phenomenon as the biggest reason there are so many gangs currently in Boston.

### *Gangs represent a significant alternative social system*

It is not surprising that our initial findings suggest that a violent subculture exists among gang members, with its own rules and norms which are shared, understood, and reinforced by members of the subculture. Gang members describe a system in which belonging is reinforced with violence, making it extremely difficult for certain youth to leave gang membership.

Further analysis reveals, however, that this phenomenon may be more than the formation of a violent subculture. Gang members have actually formed a clan-based alternate social system where gang affiliation supersedes normal familial and cultural associations, and membership is associated with a radical shift in identity. They describe in detail the breakdown of the typical nuclear family and extended family system. A number of cases

were given where gang members had relatives in rival gangs. They described having no sense of remorse with engaging in violent conflict or killing a biological relative.

In the absence of father figures or respected older men, gang-involved youth have created *tribes without elders*. These groups take on a shared worldview and the responsibility to provide financial stability and personal security for gang members. Membership is meant to be life-long and expected to supersede or replace normal familial affiliations.

The increasing failure of the traditional family social order in vulnerable communities may explain the attractiveness of joining an alternate social system that promises stability and safety. Viewing gangs as a social system instead of simply a criminal problem may expand the scope of inquiry broadly enough to allow for an appropriate solution approach to be implemented in addressing this problem.

## Conclusion

I have come to the conclusion that the results that we experienced in the Youth Violence Systems Project in engaging gang members and community residents in problem solving is attributed to the process we employed. Deeper insights were possible because deeper relationships were formed with those who know the most about the problem. In fact, the only way to understand the phenomenon of gang violence is to understand the internal logic and behavior of gang members. To gain this understanding, you must have deep trusting relationships with gang members that have been built over years. The success of YVSP in engaging gang members rests entirely upon the decades of work laid by the Boston TenPoint Coalition and our other gang consultants. It would have been impossible to gather so much information in so short a time if not for the extension of trust we were afforded because of our gang worker partners.

Finally, the establishment of a collaborative, exploratory inquiry process which respected the unique contribution of as many stakeholders as possible, allowed us to make significant progress toward creating a systems view of gang violence in Boston. Without these methods and key relationships, none of these results would have been possible.

I am convinced now more than ever, that the problem of gang violence hasn't been solved because all too often we have failed to acknowledge what we don't know. Furthermore, we have continued to use the wrong approach, wrong tools, and wrong people to solve this problem. But there is hope. The success experienced by the Youth Violence Systems Project in developing a shared framework that many people are finding useful suggests that there is another way to approach the problem that uses collaborative methods to solve a messy problem using an exploratory inquiry process.

It is now time to develop, test, and refine these tools and approaches for broader use. For each day gang violence is allowed to continue: hope is lost; criminal institutions grow in strength; and our young people perish. Together we must decide that the gang problem can be solved and that we will prioritize working together until it is eradicated from our most vulnerable communities. Equipped with the right tools, the right approach, and the right people we can solve the problem of gang violence in time to save this generation of young people.

- 
- <sup>1</sup> FBI statistics show that since 2003, Saginaw, MI, has remained the most violent city per capita in the U.S., for cities with populations greater than 50,000.
- <sup>2</sup> I use the term “gang violence” to refer to violence committed by street gangs as well as small crews whose members are not gang members but they do collectively participate in criminal activity. This is distinctly different than general, interpersonal violence committed by individuals.
- <sup>3</sup> Rittel, H & Webber, M. Dilemmas in a General Theory of Planning. Amsterdam: *Policy Sciences*, 1973 (4): 155-169.
- <sup>4</sup> Denning, P. Mastering the Mess. *ACM Communications*, 50(April); 2007: 21-25.
- <sup>5</sup> Denning, P. Resolving Wicked Problems through Collaboration. Hershey, PA: *Handbook of Research on Socio-Technical Design and Social Networking Systems*, 2009 (2): 716.
- <sup>6</sup> Howell, J. & Decker, S. The Youth Gangs, Drugs, and Violence Connection, Washington, DC: U.S. Department of Justice, Office of Justice Programs, Office of Juvenile Justice and Delinquency Prevention; 1999.
- <sup>7</sup> Denning, P. 2009 *ibid*.
- <sup>8</sup> Roberts, NC. Wicked Problems and Approaches to Resolution. *The International Public Management Review*, 2000 (1).
- <sup>9</sup> Senge, P., Kleiner, A., Roberts, C., Ross, R., Roth, G. & Smith, B. The Dance of Change: The Challenges of Sustaining Momentum in Learning Organizations. New York, NY: Doubleday/Currency; 1999: 54.
- <sup>10</sup> Denning, P. 2009 *ibid*.
- <sup>11</sup> He was shot in the face in front of his grandmother’s house and had a car repeatedly driven over his chest, caving it in, to prevent an open-casket funeral.
- <sup>12</sup> Hodge J., Hollin C.R., McMurrin M. Addicted to Crime? Hoboken, NJ: John Wiley & Sons Ltd.; 1997.



## WHAT WE ARE LEARNING

“The whole community needs to come together to fight violence.”  
—Youth at DSN Learning Center

The Youth Violence Systems Project (YVSP) was initiated to empower the community’s perspective on youth violence in Boston by creating a framework for developing intervention strategies that lead to real change. Since 2008, YVSP has been using a community-based approach coupled with systems dynamics modeling to create a virtual laboratory to model youth violence intervention strategies. Our goal is to help develop the capacity for deep and honest dialogue among a wide range of people to collaborate toward a shared goal of reducing youth violence in our neighborhoods.

This article describes how the model is being used in various settings, and what different folks are learning from the discourse so far. In addition, the story of the YVSP process is further told in three related articles:

- **The Youth Violence Systems Project: A Community-Based Framework of Understanding Youth Violence in Boston** gives an overview of the community-based process that is at the heart of YVSP. It also gives a brief introduction to the content covered in more depth in the other three articles.
- **The YVSP Strategy Lab** describes YVSP’s system dynamics model in detail, including an introduction to the key systems concepts for understanding the model.
- **The Reason Why We Haven’t Solved the Gang Violence Problem** discusses how the YVSP team solicited the input of gang members in the design process, and describes the findings and insights gained.

The power of the YVSP model to provide a shared framework of understanding and a shared language for communication about youth violence is becoming clearer and clearer. Organizations not only are gaining a deeper understanding of how their own work serves to reduce youth violence, but they can easily appreciate the approach taken by another group from their own or a different neighborhood when it’s demonstrated through the model and talked about in its now-familiar terms. These groups can then celebrate the value of their combined efforts and take a larger, systemic view that shows how they can partner together to better serve youth as well as communicate more broadly about what works for their communities. Even as these organizations are coming together with each other, they already want to take the model further and include more people in the conversation: particularly government leaders, law enforcement, and funding organizations.



## Community Forum: Organizations Learning Together

One place that really demonstrated the emerging power of the model for communication and shared understanding was the YVSP Community Forum that took place in December 2010. There were almost 70 people there representing around 20 organizations. These participants were from many different Boston neighborhoods including Uphams Corner, Bowdoin/Geneva, Grove Hall, Dudley, and other areas historically associated with high occurrence of youth violence. They were a diverse group with respect to age, race, and experience. If you heard the group talking together about their efforts to reduce youth violence and to promote peace, you would think they had always talked together in these ways. There were common terms in use throughout and a clear facility with the model. The surprise is that this common language and shared framework are new. They came about through the hard work of these same communities' members and others from their neighborhoods to build that framework together. We are seeing the payoff of all that hard work now as people are better able to communicate effectively about youth violence and work together toward improving all our neighborhoods. The more the model is used and refined, the more the momentum builds for it to be an effective framework and tool for dialog, collaborative decision making, and thoughtful action.

“And I think that this is what [the forum] is about... about each of us saying that we all have a vested interest in peace and transforming our communities and helping each other and not being about just ‘me, myself, and I’ but ‘us and we.’”

—Manny Tikili, Emcee, Community Forum

Everyone at the forum enjoyed themselves and were moved by the stories of the presenters and engaged by the “what next?” dialog of the Q&A time. For those who have been involved in the Project since the early days, it was amazing to see that the things that had been envisioned—the shared framework and common language of the model—were really happening. People were able to come together around their common concerns, speak in a shared language, and still preserve their unique roles and neighborhood-specific views. They were able to think together in a systemic way.

Toward the beginning of the meeting there were small ad hoc groups drawing and writing together about what peace means to them. One of the themes across the groups was “unity.” The forum itself was a picture of this unity where, with all these different groups working each in their own way in their own neighborhoods, there was the power to unite around the overarching vision of peace in all of our communities.

## Learning Centers and Youth Worker Trainings: Who is using the model?

The excitement of the forum was that it was a place where groups were talking and thinking together about what will best serve us across the board and how we can each play our part. The main portion of the evening was presentations by representatives of Project RIGHT, the Louis D. Brown Peace Institute, Dudley Street Neighborhood Initiative, the Catholic Charities Teen Center at St. Peter's, and Bridging the Gap (Salvation Army).

Through these presentations we got a glimpse of the many ways the model is being used by different organizations.

Several organizations have convened Learning Centers where they are using the model to deepen their understanding of their own organizational mission and their influence on reducing youth violence.

### *Catholic Charities Teen Center at St. Peter's*

The Catholic Charities Teen Center at St. Peter's (a partner organization that also participated in the Bowdoin/Geneva Design Team) has hosted two types of Learning Centers. In the summer, the Teen Center's youth met to learn about the model, youth violence in general, and the possibilities of reducing youth violence within their own community. One very revealing observation at this meeting was the youth's perception of the key purpose of law enforcement as "reducing high-risk interactions," over the traditional role of "clearing the streets."

In addition to this summer meeting of youth, the Teen Center's youth workers met during the fall as a Learning Center. After getting a handle on the framework and the model, they were able to go deeper into an analysis of their own programs and their influence at various points along the slippery slope. They presented their analysis at the Community Forum and ran a demo where they pulled the switches for "reduce recidivism," "stay off the edge," "reduce organized gang violence," and "reduce addiction to violence." They chose these four switches as being representative of the influence of their current programming. They also have clarified their focus on younger, easier-to-reach members of their community to prevent their entrance into gang activities. Through the use of the model the Teen Center was not only able to understand better what their own work is, but also to demonstrate it clearly to others familiar with the model.



*"We have some talented members of our community. Instead of them having an outlet to express everything that they are able to, they're going out and doing violent things. Instead, if we can get them into the Teen Center or different programs that are all here today then we can advocate for peace instead of continue to fall into this cycle of violence."*

*—Presenter, St. Peter's Teen Center, Community Forum*



### *Project RIGHT*

Peer leaders and outreach workers from Project RIGHT (PRI), a YVSP partner since the Grove Hall Design Team, met together as a Learning Center during the fall of 2010. During those sessions they learned about systems thinking and the YVSP model. They were able to connect

“And with this software, you could spend more time trying to actually do work rather than trying to figure stuff out that you think will work and then you put out there in the streets that don’t work, but with this it’s giving you a simulation... it shows you if you start here, this is the results... if you start with the gang leaders, these are the results you get.”

—Kevin Thomas, outreach worker

this learning with an extensive survey of youth in the Grove Hall area that they had conducted during the summer. The survey was a collaborative effort designed by PRI, Boston TenPoint Coalition, and other community partners to interview “disconnected youth”—youth aged 18-24 who are not working or in school—about topics like education, court involvement, and community involvement.

At the Community Forum, the team from PRI presented their survey findings and synthesized the findings with the YVSP model. Through their learning in the summer and fall, they chose to target “early retirement” of gang leaders on the assumption that if the leaders left the gang, so would the other members. They pulled that switch

in their demo along with “reduce less-organized gang recruiting,” since the gangs in their area tend to be less-organized and as the leaders move on, recruitment declines.

### *Dudley Street Neighborhood Initiative*

Dudley Street Neighborhood Initiative (DSNI) has been a community partner from the earliest Design Team and throughout the Project. In the summer of 2010, they created a Learning Center with a dozen youth and four adults as a part of GOTCHA (Get Off the Corner Hanging Around). For the first five meetings, the youth were trained on systems thinking and then worked—or as they reported it, “played”—extensively with the Model itself. In their sixth week, they turned around and taught what they’d been learning to the DSNI staff. As DSNI Board member Paul Bothwell talked about this teaching time, he said, “That was beautiful—seeing the youth teaching these other folk about understanding, using [the model] and about long-term consequences.”



“Everyone approaches violence differently, and you have to take action, and you have to have different intervention skills and strategies.”

—DSNI youth (learning center)

Time and time again, we see young people really taking to systems concepts and the model quite easily. It seems mostly to serve the purpose of giving language to things that they already know intuitively. The DSNI youth really grasped how this model works, and they left their time with several key realizations: that youth violence can be changed, that working in isolation may not help (or may even hurt) the situation, and that coordinating efforts can make a real difference. At the Community Forum, a young woman named Jessica reflected that from this time of working with the model, she had “learned the different ways that violence affects people in the community, and there are different

solutions to handling violence.” She also learned about “long-term effects” and realized “how bad the community trauma is.”

Jessica also commented that these youth have continued to engage in “positive activities.” She said, “We partake in the Dudley youth council where we host radio shows and we talk about topics such as education, school closing, violence... things that matter most to the youth.”

### *Others using the model*

The goal of this phase of the Project is to broaden the base of users of the model. The location-based Learning Centers are one way that broadening is happening. neXus Boston is already a learning community of local youth workers. They are using the model now to train youth workers and facilitate a role-based Learning Center for these workers. There are also other interested individuals and agencies receiving training during this phase.

#### *Joel Furrow, Bridging the Gap*

Joel Furrow of Bridging the Gap (Salvation Army) is one of the youth workers trained through neXus Boston. He presented at the Community Forum about how he has already been able to use the model in framing his work with court-referred youth. They target these areas: “stay off the edge,” “reduce recidivism,” “reducing the likelihood of gun use,” and “stay uninvolved.” He mentioned the immense value of the model in helping them to plan, to communicate with others in their organization, and, beyond just their program, to find the most strategic ways to collaborate in working toward peace together. Like many others present at the forum, he also expressed the encouragement of seeing so many people gathered together around a common goal of peace.



“We have our own opinions and our own ideas about what needs to happen in order for [peace] to take place, and this model is a framework...It gives us ways to communicate that we’re not stepping on each other’s toes.”

—Joel Furrow, *Bridging the Gap*, Community Forum



#### *Tina Chery, Louis D. Brown Peace Institute*

Tina Chery, founder of the Louis D. Brown Peace Institute (named in honor of her own son who was killed because of gang violence), has been involved with the development of the model by participating in both the psychology team and by gathering the group of mothers of killed youth who contributed their views to the model. She spoke at the forum about her desire for training on the model because she sees the value of it to contribute both to the internal workings of her organization and to inspire the overall collaboration of many organizations working together for

peace. She specifically encouraged those in attendance at the forum to “stay committed” for the long term.

“I believe this system that’s here can give us what it is that we’re looking for if we truly stay committed to it and if we move away from self and just ‘my program, my program, my youth, my quarter, my block.’ It’s about peace.”

—Tina Chery, *Louis D. Brown Peace Institute, Community Forum*

### Sharing the model more broadly

People are excited about the model and about its power to inform decision making on multiple levels: individual, organizational, community, and policy. Speaking to that last level, one of the DSNI youth who had been a part of the original Design Team spoke up during the Q&A time at the Community Forum and asked if we could have a future forum and “invite the governor or the mayor to actually play with [the model].” Her comment sparked several other comments about broadening the conversation to include others like police or funders, too. The various responses agreed with her thinking and were along the lines of getting the word out to others who are interested and have influence over the system and the resources available to those doing the front-line work at whatever point along the “slippery slope.” In particular, there was interest in being able to articulate clearly the associated costs of intervention at various points.

This Project has been characterized by a thoughtful, deliberate process, and this stage will be no different. We are aware of the potential of this tool to inform a community-centered process and empower community members to strategize about ways to achieve a long-term reduction in violence. On the other hand, it could be taken and misused in an ultimately divisive and counterproductive way. We will therefore keep to the same types of thoughtful processes we’ve used all along to accomplish the purpose of sharing the model more broadly so that its essential orientation toward learning, sharing, and collaboration is not lost.

“We are all in this together.”

—Manny Tikili, *Emcee, Community Forum*